

TOSHIBA
Leading Innovation >>>

Variable Speed Drive

TOSVERT VF-AS3

For users of the products : Our variable speed drives are designed to control the speeds of three-phase motors for general industry.

⚠ Precautions

- * Please read the instruction manual before installing or operating the drive unit.
- * This product is intended for general purpose uses in industrial application. It cannot be used applications where may cause big impact on public uses, such as power plant and railway, and equipment which endanger human life or injury, such as nuclear power control, aviation, space flight control, traffic, safety device, amusement, or medical.
It may be considerable whether to apply, under the special condition or an application where strict quality control may not be required. Please contact our headquarters, branch, or local offices printed on the front and back covers of this catalogue.
- * When exporting Toshiba variable speed drive separately or combined with your equipment, please be sure to satisfy the objective conditions and inform conditions listed in the export control policies, so called Catch All restrictions, which are set by the Ministry of Economy, Trade and Industry of Japan, and the appropriate export procedures must also be taken.
- * Please use our product in applications where do not cause serious accidents or damages even if product is failure, or please use in environment where safety equipment is applicable or a backup circuit device is provided outside the system.
- * Please do not use our product for any load other than three-phase motors.
- * None of Toshiba, its subsidiaries, affiliates or agents, shall be liable for any physical damages, including, without limitation, malfunction, anomaly, breakdown or any other problem that may occur to any apparatus in which the Toshiba variable speed drive is incorporated or to any equipment that is used in combination with the Toshiba variable speed drive. Nor shall Toshiba, its subsidiaries, affiliates or agents be liable for any compensatory damages resulting from such utilization, including compensation for special, indirect, incidental, consequential, punitive or exemplary damages, or for loss of profit, income or data, even if the user has been advised or apprised of the likelihood of the occurrence of such loss or damages.

For further information, please contact your nearest Toshiba Representative or International Operations-Producer Goods. The information in this brochure is subject to change without notice.

TOSHIBA

Toshiba Industrial Products and Systems Corporation
Global Sales Department Motor Drive Division
580, Horikawa-cho, Saiwai-ku,
Kawasaki, Kanagawa 212-0013, Japan
Tel : +81-44-520-0828
Fax : +81-44-520-0508



High-performance Drive TOSVERT VF-AS3

Variable Speed Drive for Industry



Built-in Ethernet



Real Time Clock



Web Server



QR Code®



Video Guidance



Remote Sensor Monitoring

IoT / Industry 4.0 Ready

The high performance TOSHIBA VF-AS3 achieves high speed/real time network communication via embedded Ethernet without any optional devices, ready to meet the requirement of modern automation with IoT and Industry 4.0.

Also, VF-AS3 with TOSHIBA excellent motor control technology and hardware design helps for all your applications.



Voltage class	HD	Applicable motor capacity (kW) : Multi ratings																						
		0.4	0.75	1.5	2.2	4.0	5.5	7.5	11	15	18.5	22	30	37	45	55	75	90	110	132	160	200	220	280
ND		0.75	1.5	2.2	4.0	5.5	7.5	11	15	18.5	22	30	37	45	55	75	90	110	132	160	200	220	280	315
3ph-240V class (IP20/IP00)			A1	A2	A3	A4	A5	A6																
3ph-480V class (IP20/IP00)				A1	A2	A3	A4	A5	A6	A7	A8													
3ph-480V class (IP55)				A1E	A2E	A3E	A4E	A5E																

*A1 to A8 and A1E to A5E show frame size of the drives

Contents

Evolution to IoT-Ready drive..... P3	Standard specifications P10	For drive users P19
Ideal for various applications..... P5	External dimensions P15	Peripheral devices P23
All-in-One. Improvement in Usability..... P7	Standard connection diagrams P17	Insert type options P24
Basic functions P9	Terminal functions P18	Totally enclosed box type for IP55 P34

Evolution to IoT-Ready drive.

The VF-AS3 is an IoT-Ready variable speed drive. Using Internet, the VF-AS3 provides various solutions to you.



Built-in Dual Ethernet Port

The VF-AS3 has an embedded Ethernet dual port adaptor that can be used in the following Modbus TCP and EtherNet/IP. The adaptor provides a set of services at the Ethernet and TCP/IP level.

The dual Ethernet port adaptor offers an embedded Web server which offers comfortable displaying and commissioning functions directly from a standard web browser.

The VF-AS3 supports the following Automatic IP address assignment via BOOTP and DHCP and Diagnostics and configuration via integrated Web server.

Remote Sensor Monitoring

The sensor which is equipped in the machine and equipment, can be connected with VF-AS3 and the status can be monitored by network communication.



IoT Systems Solution

-Ideal for Plant & Process Control Application

The VF-AS3 can be connected with various devices through local area network, wireless network, and the Internet. It achieves data collection to know operational status and analyze system failure.

This IoT-Ready function increase productivity and reduce total cost.

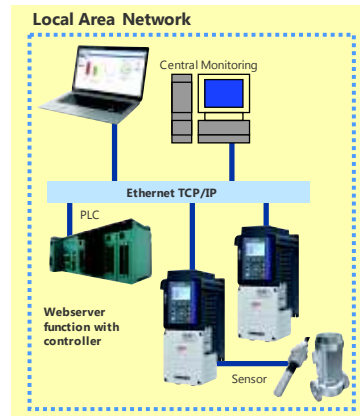

Web Server

The VF-AS3 has an embedded Web Server function, and it can be easily accessed and manage the operating condition remotely from your PC or Smart Phone/tablet devices. It can be monitored by standard web browser without any special software.

The widgets can be customized easily. The integrated web server is ideally suited for applications in which no special software or version dependencies are desired.

The product supports the following functions on Web server:

- Drive monitor
- Drive parameters read/write
- Trip history viewer
- Network parameter setting
- Administration function
- TCP/IP statistics monitor



QR Code®

For the advanced information and the event of drive fault, VF-AS3 displays the QR Code®(1), which will provide immediate access to a dedicated web link for support and maintenance.

(1) QR Code® is registered trademarks of DENSO WAVE INCORPORATED

Video Guidance

For the installation, setup and maintenance, the video guidance is available with web support.

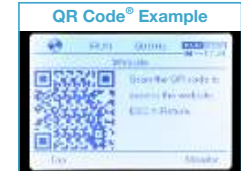

Real Time Clock - Calendar/Time Stamp function

The VF-AS3 has RTC (Real Time Clock) built-in. The calendar (work day, holiday, etc.) can be easily set by parameters.

Output terminal signal is ON at the day of the week, hour and minute set as "work day-time" by parameters.

The output terminal signal can be used as machine operation, pattern operation, and my function in the drive.

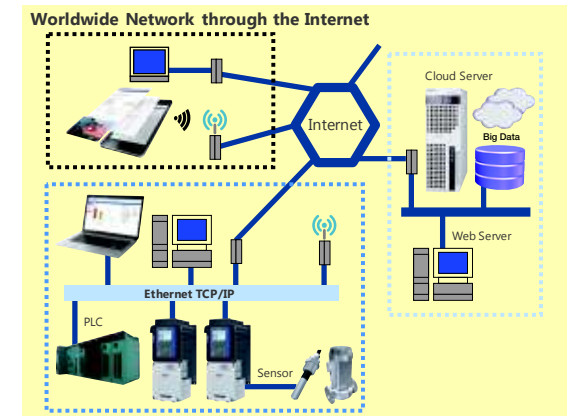
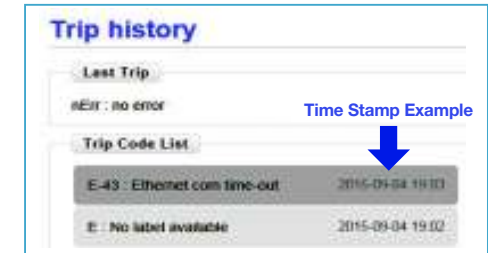

Ideal for various applications.

The VF-AS3 has various functions dedicated to various applications. The VF-AS3 will be the ideal choice for a wide variety of uses.

For Oil & Gas / Mining Industry

Jack pumps / Compressor / Conveyor / Crushers

Multi ratings – excellent motor control performance

The VF-AS3 has the multi ratings and can drive for various application with HD(150%-60sec) and ND(120%-60sec). It is available for both heavy-load application and light-load application.

The starting torque with sensor-less vector control is 200% with 0.3Hz or more. The VF-AS3 achieves high starting torque and high accuracy regenerative torque at low frequency.

Easy to set up with Auto-tuning function

The VF-AS3 has the Auto-tuning function that automatically optimizes the drive parameters.

The moment of inertia of machine and equipment can also be set easily by Auto-tuning function.

PM motor drive

PM motor drive technology has been implemented in VF-AS3 as a standard feature. The VF-AS3 can control both induction and permanent magnetic synchronous motors with/without feedback sensor, allowing them to use for the variety of purposes.

The VF-AS3 can drive both interior permanent magnetic motor (IPM) and surface permanent magnetic motor (SPM).

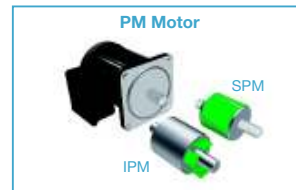
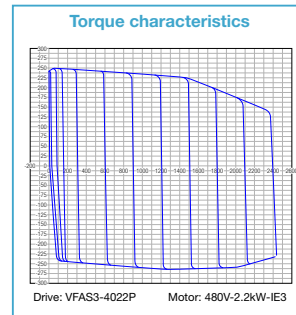

For Water & Wastewater Industry

Fan / Pump / Centrifuges

Multi pump control – maximum 10 pumps

The VF-AS3 can drive multiple pump motors (maximum ten pumps) and save the power of water pump system by controlling each pump appropriately, realizing great cost reduction.

Each pump is connected to commercial power via magnetic contactor which is controlled by relay output signal of the drive.

There are 3 relay output terminals on the drive. Furthermore, two I/O extensions can be inserted to the drive. Each I/O extension has 3 relay output terminals, and thus a maximum of 9 relay output terminals can be used.

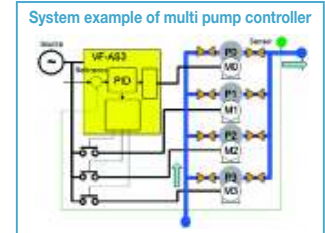

Space-saving and cost reduction by four embedded PID controllers

VF-AS3 has four built-in PID controllers: two for drives (motors) and other two for other devices including heaters and valves. The built-in PID controllers are available at the same time for many purposes. It can help reduce cost and space because it can omit additional external PID controllers.

The PID functions include temperature or pressure control of fan and pump, speed control of a winder, stop position control, etc.

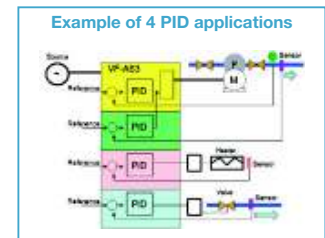

For Conveyor / Crane Industry

Transportation machine / Conveyor / Crushers / Compressor

Embedded positioning control

VF-AS3 has sensor / sensor-less position control with point to point, Pulse input and Orientation, which is suitable for applications such as processing machine for high precision control.

Excellent flexibility by My Function (logic function)

My function adds programming capability to the drive's input/output signals without external relays or PLC (programmable logic controller). The function makes it possible to reduce the space and cost required for the system.

My function has the relay sequence function that combines logic operation functions. The relay sequence function enables the drive to perform itself in 52 steps (4 steps x 7 units + 24 steps) without PLC. The processing speed is faster than control with PLC as the function uses internal data and signals directly.



For Chemical / Pharmaceutical Industry

Pumps / Mixers / Compressor / Centrifuges / Fans

Enhanced environment resistance

- Comply with the chemicals (3C3)/dust (3S3) standards of IEC60721-3-3. (Frame size A6 or smaller)
- Can be used at an altitude of up to 4800 m. (Frame size A6 or smaller)
- The inverter is operable at an ambient temperature of -15 to +60°C. (Frame size A7, A8: -10 to +60°C)
- The design expectancy life time of the cooling fan, smoothing aluminum electrolytic capacitor for power circuit, and aluminum electrolytic capacitor for control circuit are ten years. (Fan of frame size A7, A8: Five years)

* Average ambient temperature 40°C, load factor 80% or less, 24-hour and 365 days operation



All-in-One. Improvement in Usability.

The VF-AS3 allows various functions without external options.
The VF-AS3 realizes improvement in usability and cost reduction.
Not necessary to prepare optional devices separately.

Reliable safety function

The VF-AS3 has STO (Safe Torque Off) function as standard and is highly reliable to cut off output in an emergency.

The STO function brings the machine safely into a no-torque state and prevents it from starting accidentally.

It complies with safety standard IEC 61800-5-2 and also achieves SIL3 level in IEC 61508 : 2010.

In addition, the following safety functions are available as options:

- SS1 (Safe Stop 1)
- SOS (Safe Operating Stop)
- SS2 (Safe Stop 2)
- SBC (Safe Brake Control)
- SLS (Safely-Limited Speed)
- SDI (Safe Direction)

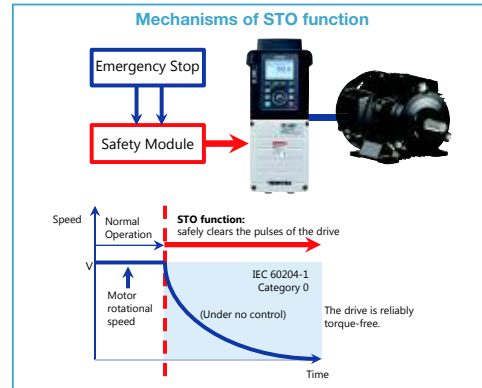

Harmonics reduction

The VF-AS3 is very friendly to a power supply system and peripheral equipment. The built-in dual DC reactor^(*) suppresses harmonic current and improves power factor.

VF-AS3 complies with IEC61000-3-12 and achieves total harmonic distortion (THD) $\leq 48\%$ without external reactor. (480V Class only)

(*) Frame size A7, A8: Attached DCL

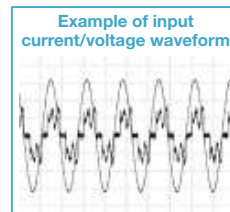

High-frequency noise reduction

The built-in EMC filter suppresses high frequency noise. The filter is ideal for sites such as commercial facilities, offices and factories where attentions must be paid to peripheral devices.

The VF-AS3 complies with EMC directive of IEC61800-3 Category C2/C3 without external filter. (480V Class only)

In addition, the VF-AS3 has built-in UL Type 1 terminal box integrated with EMC plate.

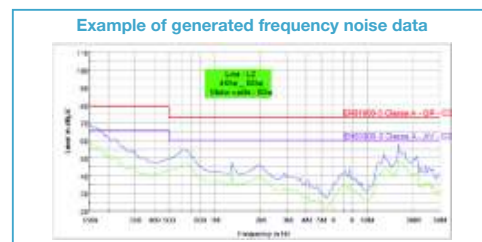
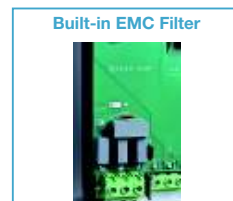

Detachable operation panel

The operation panel is detachable and easy to attach an external control console with door mounting kit. The optional panel is not required.

The protection level of the keypad is enclosed type with door mounting kit, which means dust-proof and wash-down capable.

The touch wheel has high sensitivity, which allows easy, smooth operation.



Wide, multi-language LCD screen (HMI)

The wide LCD screen (240 x 160 dots) displays multiple items at the same time, allowing easy setting of parameters.

If the VF-AS3 trips, the panel will turn red in back light color, and it's easy to recognize.

The panel can be displayed in multiple languages including German, Italian, Spanish, French, Portuguese, Russian, Chinese and Japanese as well as English.

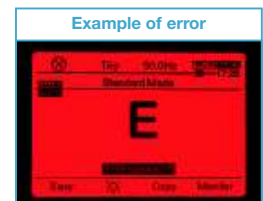
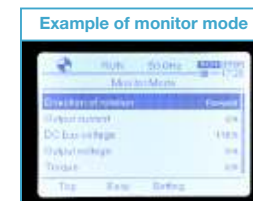

Detachable control terminal block

Detachable terminal block allows you to use the current control wiring when replacing the drive. It also makes maintenance much easier.



Various options

If more additional options are required, cassette-type options for network, extended terminal block, sensor feedback, and safety function can be added easily.

Communication network:

PROFINET^(*), PROFIBUS-DP^(*), DeviceNet^(**), EtherCAT^(***), CANopen^(****)

(*) PROFINET and PROFIBUS-DP are registered trademarks of PROFIBUS and PROFINET International .

(**) DeviceNet™ is a registered trademark of ODVA.

(***) EtherCAT™ is a registered trademark of Beckhoff Automation .

(****) CANopen® is a registered trademark of CAN in Automation.

Inputs/Outputs:

Digital & Analog I/Os: 6-Digital Input, 2-Digital Output, 2-Analog Input
Relays: 3-Relay

Safety:

Safety option (SS1, SOS, SS2, SBC, SLS, SDI)

Sensor feedback:

Digital encoder: RS422 Line receiver
Resolver

Slots for options



Cassette-type options



Basic functions

Each "setup item" that determines the control characteristics of the drive is called a "parameter". For example, to change the acceleration time, you choose the acceleration time parameter (titled "ACC").

Easy mode

To enter the Easy mode, press the F1 to F4 key of Easy marking on the panel. In this mode, you can set ten of the basic parameters.



Setting mode

In this mode, you can set all parameters. For details of parameters, refer to the Instruction Manual.

Title	Parameter name
CMOD	Run command select
FMOd	Frequency command select 1
ACC	Acceleration time 1
dEC	Deceleration time 1
UL	Upper limit frequency
LL	Lower limit frequency
thRA	Motor overload protection current 1
FM	Terminal FM adjustment
F701	Current, voltage units select
PSEL	Parameter mode select

Basic parameters

Title	Parameter name	Adjustment Range	Default setting
FC	Panel run frequency	LL-UL Hz	-
Title	Parameter name	Adjustment Range	Default setting
AUH	History function	-	-
AUF	Guidance function	0: - 1:Embedded Ethernet setting 2:Preset speed operation 3:Analog frequency command 4:Motor 1,2 switching 5:Motor parameter 6:PM motor parameter	0
AUA	Application easy setting	0: - 1:Initial easy setting 2:Conveyor 3:Material handling 4:Hoisting 5:Fan 6:Pump 7:Compressor	0
AUE	Eco-standby power setting	0: - 1:Embedded Ethernet OFF	0
AUL	Multi-rating select	0: - 1: 2:ND rating(120%-60%)0 after execution 3:HD rating(150%-60%)0 after execution 4:8-	0
AU1	Automatic Acc/Dec	0:Disabled 1:Automatic Acc/Dec 2:Automatic Acc only	0
AU2	Torque boost macro	0:Disabled 1:Automatic torque boost + offline auto-tuning 2:Vector control 1 + offline auto-tuning 3:Energy savings + offline auto-tuning	0
CMOD	Run command select	0:Terminal 1:Operation panel, Extension panel 2:Embedded Ethernet 3:RS485 communication(connector 1) 4:RS485 communication(connector 2) 5:Communication option	0
FMOd	Frequency command select 1	0: - 1:Terminal RR 2:Terminal RX 3:Terminal II 4:Terminal AH(option) 5:Terminal A5(option) 6-9: - 10:Touch wheel 1(power off or press OK to save) 11:Touch wheel 2(press OK to save) 12:SR 13-14: - 15:Terminal Up/Down frequency 16:Pulse train 17:High resolution pulse train(option) 18-19: - 20:Embedded Ethernet 21:RS485 communication(connector 1) 22:RS485 communication(connector 2) 23:Communication option	1
Pt	V/f Pattern	0:V/f constant 1:Variable torque 2:Automatic torque boost 3:Vector control 1 4:Energy savings 5:Dynamic energy savings(for fan and pump) 6:PM motor control 7:V/f 5-point setting 8: - 9:Vector control 2(speed/torque) 10:PG feedback control 11:PG feedback vector control(speed/torque) 12:PG feedback PM motor control	0
vb	Manual torque boost 1	0.00-30.00 %	Depends on the capacity
vL	Base frequency 1	15.0-590 Hz	50.0/60.0
vLv	Base frequency voltage 1	240V class:50-330 V 480V class:50-660 V	Depends on the setup menu
FH	Maximum frequency	30.0-590.0 Hz	Depends on the setup menu
UL	Upper limit frequency	0.0-FH Hz	50.0/60.0
LL	Lower limit frequency	0.0-UL Hz	0.0
ACC	Acceleration time 1	0.0-6000(600.0) sec	Depends on the capacity
dEC	Deceleration time 1	0.0-6000(600.0) sec	Depends on the capacity
SR0	Preset speed 0	LL-UL Hz	0.0
SR1	Preset speed 1	LL-UL Hz	0.0
SR2	Preset speed 2	LL-UL Hz	0.0
SR3	Preset speed 3	LL-UL Hz	0.0
SR4	Preset speed 4	LL-UL Hz	0.0
SR5	Preset speed 5	LL-UL Hz	0.0
SR6	Preset speed 6	LL-UL Hz	0.0
SR7	Preset speed 7	LL-UL Hz	0.0
FPId	PID 1 set value	F368-F367 Hz	0.0
Fr	Panel Fwd/Rev run select	0:Fwd run 1:Rev run 2:Fwd run(switchable F/R by panel) 3:Rev run(switchable F/R by panel)	0
thRA	Motor overload protection current 1	Depends on the capacity	Depends on the capacity
OLM	Motor overload protection characteristic	0:Standard motor, OL2, No stall 1:Standard motor, OL2, Stall 2:Standard motor, No OL2 trip, No stall 3:Standard motor, No OL2 trip, Stall 4:Constant torque motor, OL2, No stall 5:Constant torque motor, OL2, Stall 6:Constant torque motor, No OL2 trip, No stall 7:Constant torque motor, No OL2 trip, Stall	0
FMSL	Terminal FM function	0-162	0
FM	Terminal FM adjustment	-	0
tyP	Default setting	0: - 1:50Hz setting 2:60Hz setting 3:Default setting 1 4:Clear past trips 5:Clear cumulative run time 6:Initialize type form 7:Store user settings 8:Rewrite user settings 9:Clear cumulative fan run time 10-11: - 12:Clear number of starting 13:Default setting 2(complete initialization) 14:Clear number of external equipment starting 15:Clear cumulative overcurrent time	0
SEt	Region setting check	0:Setup menu starting 1:Japan(read only) 2:Mainly North America(read only) 3:Mainly Asia(read only) 4:Mainly Europe(read only) 5:Mainly China(read only)	0
PSEL	Parameter mode select	0:Setting mode at power on 1:Easy mode at power on 2:Easy mode only	0
F1 ~ ~	Extended parameters	Set parameters in more detail	-
F9 ~ ~	Advanced parameters	Parameters with dedicated function are displayed	-
C ~ ~	Communication parameters	Parameters with communication function are displayed	-
GRU	Changed parameters search & edit	-	-

For details on extended parameters, advanced parameters and communication parameters, please visit our web site (<http://www.inverter.co.jp/>)



Standard specifications

Standard specifications

<240 V class: HD rating>

Item		Specification															
Voltage class		240 V class															
Frame size		A1			A2		A3			A4			A5			A6	
Applicable motor (kW)		0.4	0.75	1.5	2.2	4.0	5.5	7.5	11	15	18.5	22	30	37	45	55	
Applicable motor (HP)		0.5	1	2	3	5	7.5	10	15	20	25	30	40	50	60	75	
Rating	Type	VFAS3-															
	Form	2004P	2007P	2015P	2022P	2037P	2055P	2075P	2110P	2150P	2185P	2220P	2300P	2370P	2450P	2550P	
Output capacity (kVA) ¹		1.3	1.8	3.0	4.3	7.1	9.7	12.5	17.8	24.2	29.9	35.3	46.9	56.8	67.1	80.4	
Output current (A) ²		3.3	4.6	8.0	11.2	18.7	25.4	32.7	46.8	63.4	78.4	92.6	123	149	176	211	
Output voltage		3-phase 200 V to 240 V (The maximum output voltage is equal to the input supply voltage)															
Overload current rating		150%-1 minute, 180%-2 s															
Electrical braking	Dynamic braking circuit	Built-in														Optional	
	Dynamic braking resistor	External braking resistor (Optional)															
Power supply	Voltage-frequency	3-phase 200 V to 240 V - 50/60 Hz															
	Allowable fluctuation	Voltage 170 V to 264 V ³ , Frequency ± 5%															
	Required power supply capacity (kVA) ⁴	0.7	1.4	2.4	3.7	5.9	7.7	10.5	15.7	20.6	24.9	30.7	40.5	49.6	61.0	73.3	
Degree of protection (IEC60529)		IP20														IP00	
Cooling method		Forced air-cooled															
Color		RAL7016 / RAL7035															
EMC filter (IEC61800-3)	Built-in filter	-														-	
	External filter ⁵	C2-50m (Carrier frequency: 4.0 kHz), C3-150m (4.0 kHz)						C2-50m (2.5 kHz), C3-150m (2.5 kHz)						-			
DC reactor		Built-in															
UL type1 kit		Built-in														Optional	
Harmonics THD _i ≤ 48% (IEC61000-3-12)		Refer to the instruction manual for the current level															

<240 V class: ND rating>

Item		Specification															
Voltage class		240 V class															
Frame size		A1			A2		A3			A4			A5			A6	
Applicable motor (kW)		0.75	1.5	2.2	4.0	5.5	7.5	11	15	18.5	22	30	37	45	55	75	
Applicable motor (HP)		1	2	3	5	7.5	10	15	20	25	30	40	50	60	75	100	
Rating	Type	VFAS3-															
	Form	2004P	2007P	2015P	2022P	2037P	2055P	2075P	2110P	2150P	2185P	2220P	2300P	2370P	2450P	2550P	
Output capacity (kVA) ¹		1.8	3.0	4.3	7.1	9.7	12.5	17.8	24.2	29.9	35.3	46.9	56.8	67.1	80.4	107	
Output current (A) ²		4.6	8.0	11.2	18.7	25.4	32.7	46.8	63.4	78.4	92.6	123	149	176	211	282	
Output voltage		3-phase 200 V to 240 V (The maximum output voltage is equal to the input supply voltage)															
Overload current rating		120%-1 minute, 135%-2 s															
Electrical braking	Dynamic braking circuit	Built-in														Optional	
	Dynamic braking resistor	External braking resistor (Optional)															
Power supply	Voltage-frequency	3-phase 200 V to 240 V - 50/60 Hz															
	Allowable fluctuation	Voltage 170 V to 264 V ³ , Frequency ± 5%															
	Required power supply capacity (kVA) ⁴	1.2	2.3	3.3	5.9	7.8	10.3	15.0	20.6	24.9	29.4	40.5	49.3	59.6	73.3	98.1	
Degree of protection (IEC60529)		IP20														IP00	
Cooling method		Forced air-cooled															
Color		RAL7016 / RAL7035															
EMC filter (IEC61800-3)	Built-in filter	-														-	
	External filter ⁵	C2-50m (Carrier frequency: 4.0 kHz), C3-150m (4.0 kHz)						C2-50m (2.5 kHz), C3-150m (2.5 kHz)						-			
DC reactor		Built-in															
UL type1 kit		Built-in														Optional	
Harmonics THD _i ≤ 48% (IEC61000-3-12)		Refer to the instruction manual for the current level															

¹: Capacity is calculated at 220 V for the 240 V class.

²: Indicates rated output current setting when the PWM carrier frequency (parameter F300) is 4 kHz for frame size A1 to A5, 2.5 kHz for frame size A6.

³: Lower limit of voltage for 240 V class is 180 V when the inverter is used continuously (load of 100%).

⁴: Required power supply capacity varies with the value of the power supply side inverter impedance (including those of the input reactor and wires).

⁵: Contact your Toshiba distributor for detail.

<480 V class: HD rating>

Item		Specification												
Voltage class		480 V class												
Frame size		A1			A2			A3			A4			
Applicable motor (kW)		0.4	0.75	1.5	2.2	4.0	5.5	7.5	11	15	18.5	22	30	37
Applicable motor (HP)		0.5	1	2	3	5	7.5	10	15	20	25	30	40	50
Rating	Type	VFAS3-												
	Form	4004PC	4007PC	4015PC	4022PC	4037PC	4055PC	4075PC	4110PC	4150PC	4185PC	4220PC	4300PC	4370PC
	Output capacity (kVA) ^{*1}	1.1	1.7	3.0	4.3	7.1	9.7	12.6	17.9	24.2	29.9	35.3	46.9	56.8
	Output current (A) ^{*2}	1.5	2.2	4.0	5.6	9.3	12.7	16.5	23.5	31.7	39.2	46.3	61.5	74.5
	Output voltage	3-phase 380 V to 480 V (The maximum output voltage is equal to the input supply voltage)												
Overload current rating	150%-1 minute, 180%-2 s													
Electrical braking	Dynamic braking circuit	Built-in												
	Dynamic braking resistor	External braking resistor (Optional)												
Power supply	Voltage-frequency	3-phase 380 V to 480 V - 50/60 Hz												
	Allowable fluctuation	Voltage 323V to 528V ³ , Frequency ± 5%												
	Required power supply capacity (kVA) ^{*4}	0.7	1.4	2.6	3.9	6.6	8.5	11.4	16.6	22.3	27.3	32.7	44.3	53.9
Degree of protection (IEC60529)		IP20												
Cooling method		Forced air-cooled												
Color		RAL7016 / RAL7035												
EMC filter (IEC61800-3)	Built-in filter	C2-50m (Carrier frequency: 4.0 kHz), C3-150m (4.0 kHz)												
	External filter ^{*5}	C2-150m (Carrier frequency: 4.0 kHz), C3-300m (4.0 kHz)												
DC reactor		Built-in												
UL type1 kit		Built-in												
Harmonics THDI ≤ 48% (IEC61000-3-12)		Refer to the instruction manual for the current level												

Item		Specification											
Voltage class		480 V class											
Frame size		A5			A6			A7	A8				
Applicable motor (kW)		45	55	75	90	110	132	160	200	220	280		
Applicable motor (HP)		60	75	100	125	150	200	250	300	350	450		
Rating	Type	VFAS3-											
	Form	4450PC	4550PC	4750PC	4900PC	4110KPC	4132KPC	4160KPC	4200KPC	4220KPC	4280KPC		
	Output capacity (kVA) ^{*1}	67.1	80.8	111	132	161	191	239	295	325	419		
	Output current (A) ^{*2}	88.0	106	145	173	211	250	314	387	427	550		
	Output voltage	3-phase 380 V to 480 V (The maximum output voltage is equal to the input supply voltage)											
Overload current rating	150%-1 minute, 180%-2 s						150%-1 minute, 165%-2 s						
Electrical braking	Dynamic braking circuit	Built-in			Optional			Built-in	Optional				
	Dynamic braking resistor	External braking resistor (Optional)											
Power supply	Voltage-frequency	3-phase 380 V to 480 V - 50/60 Hz						3-phase 380 to 440 V - 50 Hz, 3-phase 380 to 480 V - 60 Hz					
	Allowable fluctuation	Voltage 323 V to 528 V ³ , Frequency ± 5%						Voltage 323 to 484 V - 50 Hz, 323 V to 528 V - 60 Hz ³ , Frequency ± 5%					
	Required power supply capacity (kVA) ^{*4}	65.6	79.5	108	133	155	181	225	275	308	379		
Degree of protection (IEC60529)		IP20			IP00								
Cooling method		Forced air-cooled											
Color		RAL7016 / RAL7035											
EMC filter (IEC61800-3)	Built-in filter	C3-150m (2.5 kHz)						C3-50m (2.5 kHz)					
	External filter ^{*5}	C2-150m (2.5 kHz), C3-300m (2.5 kHz)						C2-100m (2.5 kHz)					
DC reactor		Built-in			Built-in			Attached					
UL type1 kit		Built-in			Optional			-					
Harmonics THDI ≤ 48% (IEC61000-3-12)		Refer to the instruction manual for the current level											

*1: Capacity is calculated at 440 V for the 480 V class.
 *2: Indicates rated output current setting when the PWM carrier frequency (parameter F300) is 4 kHz for frame size A1 to A5, 2.5 kHz for frame size A6 to A8.
 *3: Lower limit of voltage for 480 V class is 342 V when the inverter is used continuously (load of 100%).
 *4: Required power supply capacity varies with the value of the power supply side inverter impedance (including those of the input reactor and wires).
 *5: Contact your Toshiba distributor for detail.

<480 V class: ND rating>

Item		Specification												
Voltage class		480V class												
Frame size		A1			A2			A3			A4			
Applicable motor (kW)		0.75	1.5	2.2	4.0	5.5	7.5	11	15	18.5	22	30	37	45
Applicable motor (HP)		1	2	3	5	7.5	10	15	20	25	30	40	50	60
Rating	Type	VFAS3-												
	Form	4004PC	4007PC	4015PC	4022PC	4037PC	4055PC	4075PC	4110PC	4150PC	4185PC	4220PC	4300PC	4370PC
	Output capacity (kVA) ^{*1}	1.7	3.0	4.3	7.1	9.7	12.6	17.9	24.2	29.9	35.3	46.9	56.8	67.1
	Output current (A) ^{*2}	2.2	4.0	5.6	9.3	12.7	16.5	23.5	31.7	39.2	46.3	61.5	74.5	88.0
	Output voltage	3-phase 380 V to 480 V (The maximum output voltage is equal to the input supply voltage)												
Overload current rating	120%-1 minute, 135%-2 s													
Electrical braking	Dynamic braking circuit	Built-in												
	Dynamic braking resistor	External braking resistor (Optional)												
Power supply	Voltage-frequency	3-phase 380 V to 480 V - 50/60 Hz												
	Allowable fluctuation	Voltage 323 V to 528 V ³ , Frequency ± 5%												
	Required power supply capacity (kVA) ^{*4}	1.2	2.4	3.4	6.1	8.3	10.9	15.6	21.3	26.4	31.4	42.0	52.4	63.2
Degree of protection (IEC60529)		IP20												
Cooling method		Forced air-cooled												
Color		RAL7016 / RAL7035												
EMC filter (IEC61800-3)	Built-in filter	C2-50m (Carrier frequency: 4.0 kHz), C3-150m (4.0 kHz)												
	External filter ^{*5}	C2-150m (Carrier frequency: 4.0 kHz), C3-300m (4.0 kHz)												
DC reactor		Built-in												
UL type1 kit		Built-in												
Harmonics THDI ≤ 48% (IEC61000-3-12)		Refer to the instruction manual for the current level												

Item		Specification											
Voltage class		480 V class											
Frame size		A5			A6			A7	A8				
Applicable motor (kW)		55	75	90	110	132	160	220	250	280	315		
Applicable motor (HP)		75	100	125	150	200	250	350	400	450	500		
Rating	Type	VFAS3-											
	Form	4450PC	4550PC	4750PC	4900PC	4110KPC	4132KPC	4160KPC	4200KPC	4220KPC	4280KPC		
	Output capacity (kVA) ^{*1}	80.8	111	132	161	191	230	325	367	419	469		
	Output current (A) ^{*2}	106	145	173	211	250	302	427	481	550	616		
	Output voltage	3-phase 380 V to 480 V (The maximum output voltage is equal to the input supply voltage)											
Overload current rating	120%-1 minute, 135%-2 s												
Electrical braking	Dynamic braking circuit	Built-in			Optional			Built-in	Optional				
	Dynamic braking resistor	External braking resistor (Optional)											
Power supply	Voltage-frequency	3-phase 380 V to 480 V - 50/60 Hz						3-phase 380 to 440 V - 50 Hz, 3-phase 380 to 480 V - 60 Hz					
	Allowable fluctuation	Voltage 323 V to 528 V ³ , Frequency ± 5%						Voltage 323 to 484 V - 50 Hz, 323 V to 528 V - 60 Hz ³ , Frequency ± 5%					
	Required power supply capacity (kVA) ^{*4}	77.0	103	125	155	181	214	296	335	379	422		
Degree of protection (IEC60529)		IP20			IP00								
Cooling method		Forced air-cooled											
Color		RAL7016 / RAL7035											
EMC filter (IEC61800-3)	Built-in filter	C3-150m (2.5 kHz)						C3-50m (2.5 kHz)					
	External filter ^{*5}	C2-150m (2.5 kHz), C3-300m (2.5 kHz)						C2-100m (2.5 kHz)					
DC reactor		Built-in			Built-in			Attached					
UL type1 kit		Built-in			Optional			-					
Harmonics THDI ≤ 48% (IEC61000-3-12)		Refer to the instruction manual for the current level											

*1: Capacity is calculated at 440 V for the 480 V class.
 *2: Indicates rated output current setting when the PWM carrier frequency (parameter F300) is 4 kHz for frame size A1 to A5, 2.5 kHz for frame size A6 to A8.
 *3: Lower limit of voltage for 480 V class is 342 V when the inverter is used continuously (load of 100%).
 *4: Required power supply capacity varies with the value of the power supply side inverter impedance (including those of the input reactor and wires).
 *5: Contact your Toshiba distributor for detail.

Common Specifications

	Item	Specification
Control specifications	Control system	Sinusoidal PWM control
	Output voltage adjustment	Adjustable within the range of 50 - 330 V (240 V class) and 50 - 660 V (480 V class) by correcting the supply voltage
	Output frequency range	Setting between 0.01 - 590 Hz. Default max. frequency is set to 0.01 - 80 Hz. Maximum frequency adjustment (30 to 590Hz)
	Minimum setting steps of frequency	0.01 Hz: operation panel input (60 Hz base), 0.03 Hz: analog input (60 Hz base, 11 bit/0 - 10 Vdc)
	Frequency accuracy	Analog input: $\pm 0.2\%$ of the maximum output frequency (at $25\pm 10^\circ\text{C}$) Digital input: $\pm 0.01\% \pm 0.022$ Hz of the output frequency
	Voltage/frequency characteristics	V/f constant, variable torque, automatic torque boost, vector control, PM motor control, base frequency adjustment 1, 2, 3, and 4 (15 - 590Hz), V/f 5-point arbitrary setting, torque boost adjustment (0 - 30%), start frequency adjustment (0 - 10 Hz), stop frequency adjustment (0 - 30 Hz)
	Frequency setting signal	3 k Ω potentiometer (possible to connect to 1 - 10 k Ω -rated potentiometer) 0 - 10Vdc (input impedance Zin: 31.5 k Ω) -10 to +10 Vdc (Zin: 31.5 k Ω) 4 - 20 mAdc (Zin: 250 Ω)
	Terminal block frequency command	The characteristic can be set arbitrarily by two-point setting. Compliant with 7 types of input; analog input (RR, RX, II, AI4, AI5), and pulse input (S4, S5)
	Frequency jump	Three frequency can be set. Setting of jump frequency and width.
	Upper and lower limit frequencies	Upper limit frequency: 0 to max. frequency, lower limit frequency: 0 to upper limit frequency
	PWM carrier frequency	Frame size A1 to A4: adjustable between 1.0 - 16 kHz Frame size A5 to A8: adjustable between 1.0 - 8.0 kHz
	PID control	Adjustment of proportional gain, integral time, differential time and delay filter. Multi PID and external PID control.
	Torque control	Voltage command input specification: -10 - +10 Vdc
	Operation specifications	Real Time Clock (RTC)
Acceleration/deceleration time		0.01 - 6000 sec. Selectable from among acceleration/deceleration. times 1, 2, 3 and 4. Automatic acceleration/deceleration function. S-pattern acceleration/deceleration 1 and 2 pattern adjustable.
DC braking		Adjustment of braking start frequency (0 - [FH]Hz), braking (0 - 100%) and braking time (0 - 25.5 sec.). With emergency off braking function and motor shaft fix control function.
Forward run/reverse run ¹		Forward run with ON of the terminal [F], Reverse run with ON of the terminal [R] (Default setting). Coast stop with OFF of the terminal assigned Stad-by function. Emergency off by panel operation or terminal.
Jog run ¹		Jog run, if selected, allows jog operation from the operation panel Jog run operation by terminal block is possible by setting the parameters.
Preset speed operation ¹		By changing the combination of the terminals [S1], [S2], [S3], [S4], [S5] set frequency + 31-speed operation. Selectable between acceleration/deceleration time, torque limit and V/f by set frequency.
Retry		Capable of restarting after a check of the power circuit elements in case the protective function is activated. Max. 10 times selectable arbitrarily. Waiting time adjustment (0 - 10 sec.)
Soft stall		Automatic load reduction control at overloading. (Default: OFF)
Cooling fan ON/OFF		The cooling fan will be stopped automatically to assure long life when unnecessary.
Lockout key operation/Password setting		Lock or unlock the key operation and parameter setting. Lock parameter setting with a password.
Regenerative power ride-through control		Possible to keep the motor running using its regenerative energy in case of a momentary power failure. (Default: OFF)
Auto-restart operation		Possible to restart the motor in coasting in accordance with its speed and direction. (Default: OFF)
Simplified pattern operation		Possible to select each 8 patterns in 2 groups from 15-speed operation frequency. Max. 16 types of operation possible. Terminal operation/repeat operation possible.
Commercial inverter switching		Possible to switch operation by commercial power supply or inverter
Light-load high-speed operation	Increases the operating efficiency of the machine by increasing the rotational speed of the motor when it is operated under light load.	
Protective function	Droop function	When two or more inverters are used to operate a single load, this function prevents load from concentrating on one inverter due to unbalance.
	Override function	External input signal adjustment is possible to the operation frequency command value.
	Protective function	Stall prevention, current limit, overcurrent, overvoltage, short circuit on the load side, ground fault on the load side ⁴ , undervoltage, momentary power failure (15 ms or more), non-stop control at momentary power failure, overload protection, arm overload at starting, overcurrent on the load side at starting, overcurrent and overload at braking resistor, overheat, emergency off
	Electronic thermal characteristic	Switchable between standard motor/constant torque motor, adjustment of overload protection and stall prevention level.
	Reset	Reset by 1a contact closed (or 1b contact opened), or by operation panel. Or power supply OFF/ON. This function is also used to save and clear trip records.

(Continued overleaf)

(Continued)

	Item	Specification	
Display function	Alarms	Stall prevention during run, overload limit, overload, undervoltage on power supply side, DC circuit undervoltage, setting error, in retry, upper limit, lower limit.	
	Causes of failures	Overcurrent, overvoltage, overheat, short circuit on the load side, ground fault on the load side, inverter overload, arm overcurrent at starting, overcurrent on the load side at starting, Cooling fan fault, CPU fault, EEPROM fault, RAM fault, ROM fault, communication error, (braking resistor overcurrent/overload), (emergency off), (undervoltage), (undercurrent), (overtorque), (motor overload), (input phase failure), (output phase failure) The items in the parentheses are selectable.	
	Monitoring function	Output frequency, frequency command, forward run/reverse run, output current, DC voltage, output voltage, compensated frequency, terminal input/output information, CPU version, past trip history, cumulative operation time, feedback frequency, torque, torque command, torque current, exiting current, PID feedback value, motor overload factor, inverter overload factor, PBR overload factor, PBR load factor, input power, output power, peak output current, peak DC voltage, RR input, II input, RX input, AI4 input, AI5 input, FM output, AM output, expansion I/O card option CPU version, integral input power, integral output power, communication option reception counter, communication option abnormal counter.	
	Free unit display	Display of optional units other than output frequency (motor speed, line speed, etc), current ampere/% switch, voltage volt/% switch	
	Automatic edit function	Searches automatically parameters that are different from the default setting parameters. Easy to find changed parameters.	
	User default setting	User parameter settings can be saved as default settings. Allows to reset the parameters to the user-defined parameter settings.	
	LED	Charge display	Displays power circuit capacitor charging.
	Input/output terminal logic function	Possible to select positive logic or negative logic with programmable input/output terminal function menu. 2 or 3 function can be assigned for some terminals. ¹ ² (Default setting: positive logic)	
	Sink/source switching	Possible to switch between minus common (CC) and plus common (P24) for digital input terminal. (Default setting: external power supply)	
	output signal	Failure detection signal	1c contact output (250Vac-2A (cos Φ =1), 30Vac-2A (Resistive), 250Vac=1A (cos Φ =0.4), 30Vdc=1A (L/R=7ms))
Relay output		2x1a contact output (250Vac-2A (cos Φ =1), 30Vac-2A (Resistive), 250Vac=1A (cos Φ =0.4), 30Vdc=1A (L/R=7ms))	
Low speed, Acc/Dec completed signal output ²		Digital output (24 Vdc, max. 50 mA)	
Output for frequency meter/Output for ammeter ³		Analog output for meter: 1 mA dc full-scale dc ammeter 0 - 20 mA (4 - 20 mA) output: DC ammeter (allowable load resistance: 500 Ω or less) 0 - 10 V output: DC voltmeter (allowable load resistance: 1 k Ω or more)	
Pulse train frequency output		Pulse train output (Up to 30 kpps, duty 50%)	
Communication function	Ethernet standard 2-channel equipped (connector: RJ45) IEEE802.3/IEEE802.3u (Fast Ethernet) (10/100Mbps: Auto negotiation) RS485 standard 2-channel equipped (connector: RJ45) PROFINET, DeviceNet, PROFIBUS-DP, EtherCAT are optional.		
Environments	Use environments	Indoor use. Altitude: 4800m or less for frame size A1 to A6, 3000m or less for frame size A7 and A8 (current reduction necessary when above 1000 m ⁶). Place not exposed to direct sunlight and free of corrosive and explosive gases.	
	Ambient temperature	-15 to +60°C ⁵ Frame size A1 to A5: Current reduction, remove the top cover when above 50°C; Frame size A6: Current reduction when above 50°C; Frame size A7 and A8: Current reduction when above 50°C (HD), above 45°C (ND)	
	Storage temperature	-25 to + 70°C ⁷	
	Relative humidity	5 to 95% (free from condensation)	
	Vibration	Frame size A1 to A5: 5.9 m/s ² {0.6G} or less (10 - 55 Hz), Frame size A6 to A8: 2.9 m/s ² {0.3G} or less (10 - 55 Hz)	

¹: 14 digital input terminals (of which 6 are options) are programmable digital input terminals, and they make it possible to arbitrarily select from 178 types of signals.

²: Programmable ON/OFF output terminals make it possible to arbitrarily select from 256 types of signals.

³: Programmable analog output terminals make it possible to arbitrarily select from 54 types of signals.

⁴: This function protects inverters from overcurrent due to output circuit ground fault.

⁵: -10 to 60°C for frame size A7 and A8. Remove operation panel of the inverter when above 50°C.

⁶: Current must be reduced by 1% for each 100m over 1000m, e.g. 90% at 2000m, 80% at 3000m

⁷: Temperature applicable for a short term, e.g. during transportation

External dimensions

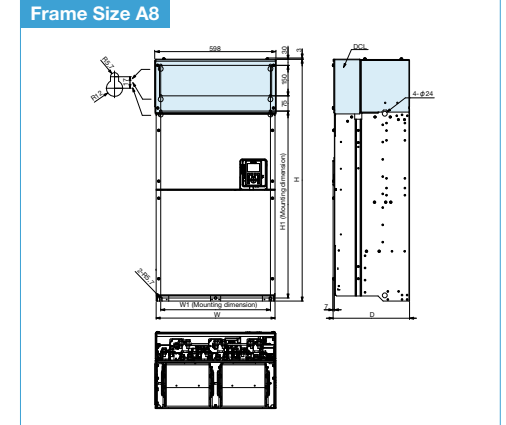
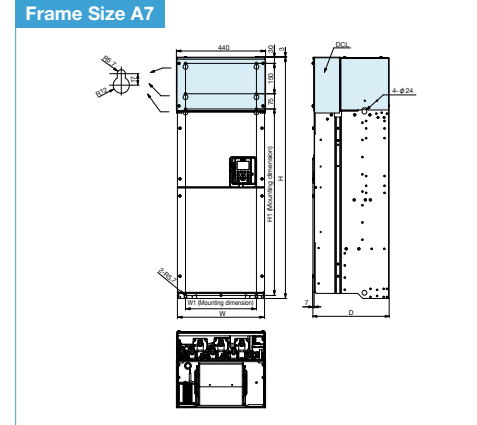
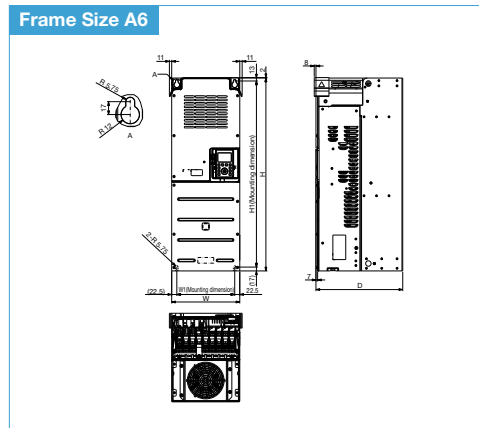
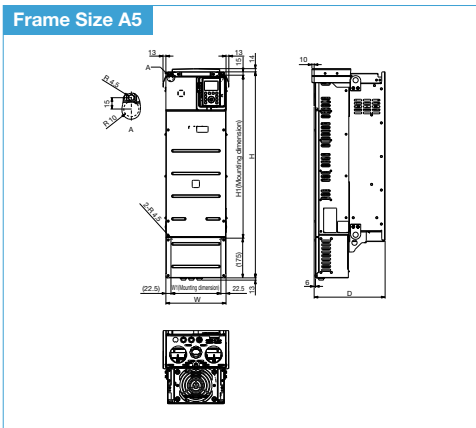
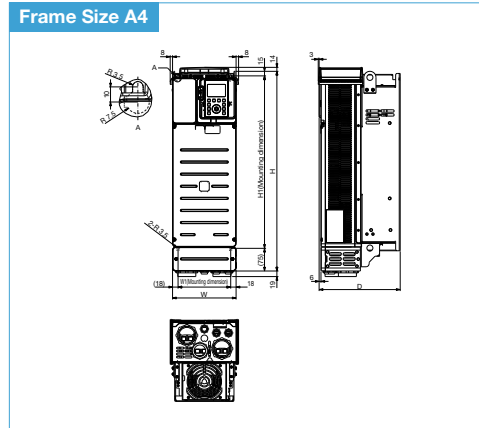
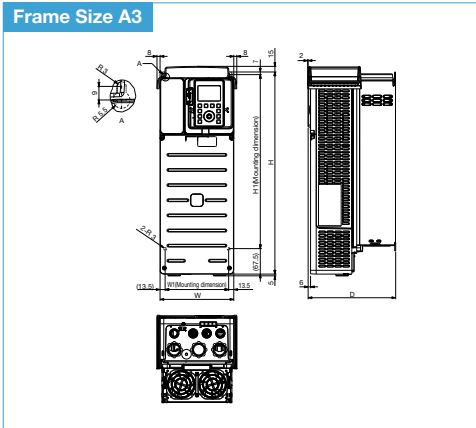
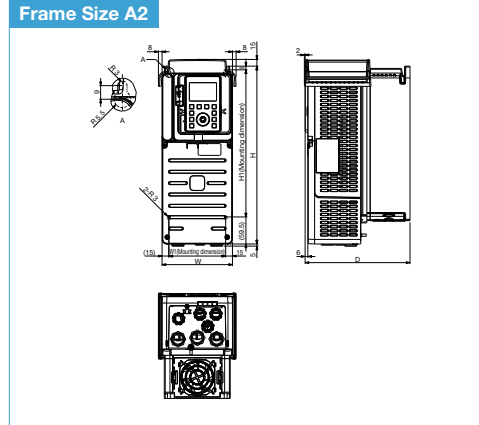
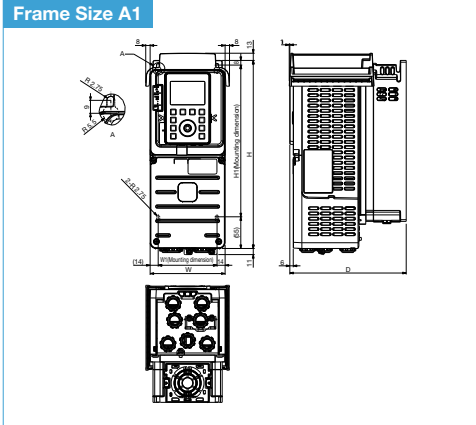

Input voltage Class	Applicable motor capacity (kW)		Drive type-form	Dimension (mm)					Frame Size	Approx. mass (kg)
	HD	ND		W	H	D	W1 *1	H1 *1		
3-phase 240 V	0.4	0.75	VFAS3-	130	326	202	102	263	A1	4.3
	0.75	1.5								4.3
	1.5	2.2								4.5
	2.2	4.0								4.6
	4.0	5.5		155	391.5	231	125	324	A2	7.7
	5.5	7.5		195	534.5	232	168	460	A3	13.8
	7.5	11								13.8
	11	15		210	660	268	174	570	A4	27.3
	15	18.5								27.3
	18.5	22								27.3
	22	30								57.6
	30	37		265	908	313	220	718	A5	57.6
	37	45								57.6
	45	55								82
	55	75								82
	3-phase 480 V	0.4		0.75	VFAS3-	130	326	202	102	263
0.75		1.5	4.5							
1.5		2.2	4.5							
2.2		4.0	4.6							
4.0		5.5	155	391.5		231	125	324	A2	7.7
5.5		7.5								7.7
7.5		11								13.6
11		15								14.2
15		18.5	195	534.5		232	168	460	A3	14.3
18.5		22								14.3
22		30								28
30		37								28.2
37		45	210	660		268	174	570	A4	28.7
45		55								28.7
55		75								57.5
75		90								59
90		110	265	908		313	220	718	A5	59.5
110		132								59.5
132		160								82
160		220								82
200		250	300	850		383	255	820	A6	82
220		280								82
280		315								110 (168) ²
										138 (200) ²
		430	1190	377	350	920	A7	140 (210) ²		
								140 (210) ²		
								140 (210) ²		
								140 (210) ²		

*1: W1 and H1 are the mounting dimensions of the drive.

*2: Value in () includes attached DC reactor.

Standard connection diagrams

Standard connection diagram : Sink logic (common : CC)

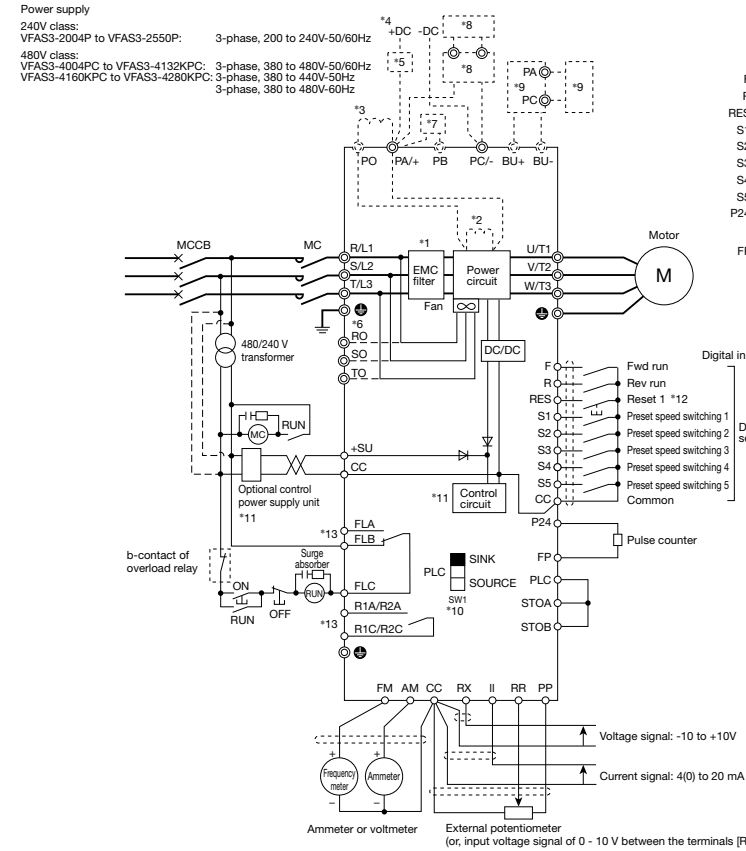

- *1: EMC filter is built in 480 V class.
- *2: The DC reactor is built in for models VFAS3-2004P to 2550P and VFAS3-4004PC to 4132KPC.
- *3: Be sure to mount the DC reactor for models VFAS3-4160KPC to 4280KPC. A circuit between the terminals [PA+] and [PO] is not short circuited (at the time of shipping).
- *4: To input DC power, connect the inverter between the terminals [PA+] and [PC-]. It is not used in conjunction with the attached DC reactor for VFAS3-4160KPC to 4280KPC.
- *5: For models of VFAS3-2110P to 2550P and VFAS3-4220PC to 4280KPC, a rush current suppression circuit (optional) is required and please contact your Toshiba distributor for information.
- *6: When the inverter is used with a DC power supply, three-phase power input for cooling fan driving is required separately for models VFAS3-4160KPC to 4280KPC.
- *7: External braking resistor (optional) for models VFAS3-2004P to 2370P and VFAS3-4004PC to 4750P, VFAS3-4160KPC.
- *8: When a braking resistor (optional) is mounted, a braking unit (optional) is also required, for models VFAS3-2450P, 2550P and VFAS3-4900PC to 4132KPC.
- *9: When a braking resistor (optional) is mounted, a braking unit (optional) is also required, for models VFAS3-4200KPC to 4280KPC.
- *10: With the slide switch [SW1] of the control terminal block, the setting of sink logic, source logic and external power supply sink logic of the digital input terminals [F], [R], [RES], and [S1] - [S5] is switched. [SW1] is set to the PLC side in the default setting. This is the setting when the inverter external power supply is used.
- *11: To supply control power from an external power supply for backing up the control power supplied from the inverter, an optional control power supply unit (CPS002Z) is required. In this case, it is used in conjunction with the inverter internal power supply. Set [F647: Control power option failure detection] to back up the control power supply.
- *12: The reset signal is activated by ON → OFF trigger input.
- *13: Connect to power to comply with OVC2 (Over Voltage Category 2). Isolation transformer is necessary when connecting to power supply (OV3C).

Standard connection diagram : Source logic (common : P24)

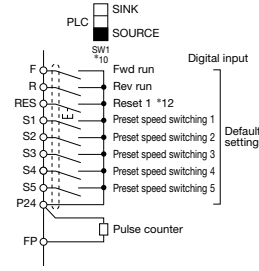

Terminal functions

Power terminal

Terminal symbol	Function	Applicable frame size
[PE]	Grounding terminal for inverter case. Grounding terminal.	All frame sizes Frame size A4, A5, and A6
[R/L1] [S/L2] [T/L3]	Connected to an AC power supply. 240 V class: Three-phase 200 - 240 V-50/60 Hz 480 V class: VFAS3-4004PC to 4132KPC: Three-phase 380 - 480 V-50/60 Hz VFAS3-4160KPC to 4280KPC: Three-phase 380 - 440 V- 50 Hz Three-phase 380 - 480 V- 60 Hz	All frame sizes
[U/T1] [V/T2] [W/T3]	Connected to a three-phase motor. Connected to a braking resistor.	All frame sizes
[PA+] [PB]	Change the parameters [F304: Dynamic braking, OLr trip], [F308: Braking resistance], and [F309: Braking resistor capacity] if necessary.	Frame size A1, A2, A3, A4, A5, and A7
[BU+] [BU-]	Inside the inverter. Connected to a braking unit (optional). Braking resistor (optional) is connected to a braking unit terminals [PA] and [PB].	Frame size A8
[PA+] [PC-]	A DC power can be input. For models of VFAS3-2110P to 2550P and VFAS3-4220PC to 4280KPC, a rush current suppression circuit (optional) is required. Connected to a braking unit (Optional) for frame size A6.	All frame sizes
[PA+] [PO]	Be sure to connect the attached DC reactor.	Frame size A7 and A8
[RO] [SO] [TO]	Inverter's cooling power input terminals. When using a DC power supply, connect three-phase power wires.	Frame size A7 and A8

Control terminal

Terminal symbol	Input/output	Function	Electrical specifications
F	Input	Multifunction programmable digital input. In the default setting, forward run is performed with ON and deceleration stop with OFF.	Digital input. •24 Vdc-5 mA or less
R	Input	Multifunction programmable digital input. In the default setting, reverse run is performed with ON and deceleration stop with OFF.	Compliant with IEC61131-2 logic type 1
RES	Input	Multifunction programmable digital input. In the default setting, this inverter protective function is reset by ON → OFF. It has no effect when the inverter is in a normal condition.	•Sink logic: ON < 10 V, 16 V < OFF •Source logic: OFF < 5 V, 11 V < ON
S1	Input	Multifunction programmable digital input. In the default setting, preset speed operation is performed with ON	Sink logic and source logic can be switched with the slide switch [SW1]
S2	Input	Multifunction programmable digital input. In the default setting, preset speed operation is performed with ON	
S3	Input	Multifunction programmable digital input. In the default setting, preset speed operation is performed with ON	
S4	Input	Multifunction programmable digital input. In the default setting, preset speed operation is performed with ON. With [F146: Terminal S4 input select], digital input, pulse train input, and PG input can be switched.	Digital input. •24 Vdc-5 mA or less Compliant with IEC61131-2 logic type 1
S5	Input	Multifunction programmable digital input. In the default setting, preset speed operation is performed with ON. With [F147: Terminal S5 input select], digital input, pulse train input, and PG input can be switched.	•Sink logic: ON < 10 V, 16 V < OFF •Source logic: OFF < 5 V, 11 V < ON Pulse train input •Up to 30 kpps (duty 50%)
CC	Common to input/output	An equipotential terminal of the control circuit. It is allocated in three positions.	-
PP	Output	10 Vdc power output for analog input setting.	10 Vdc (allowable load current: 10 mAdc)
FP	Output	Multifunction programmable digital/pulse train output. With [F669: Terminal FP switching], digital output and pulse train output can be switched.	Digital output •24 Vdc-50 mA Pulse train output •Up to 30 kpps (duty 50%)
RR	Input	Analog input with 0 - 10 Vdc. It can be switched to PTC input, etc. with [F108: Terminal RR input select].	0 - 10 Vdc (input impedance: 31.5 kΩ)
RX	Input	Analog input with -10 to +10 Vdc. With [F107: Terminal RX input voltage select], it can be switched to 0 - 10 Vdc.	-10 to +10 Vdc (input impedance: 31.5 kΩ)
II	Input	Analog current input with 0 - 20 mAdc. The current can be changed to 4 - 20 mA, etc. with setting of the parameter.	0 - 20 mAdc (input impedance: 250 Ω)
FM	Output	Multifunction programmable analog output. 0 - 10 Vdc output with default setting. With [F681: Terminal FM switching], meter option (0 - 1 mA), current (0 - 20 mA) output, and voltage (0 - 10 V) output can be switched.	0 - 10 Vdc (allowable load resistance: 1 kΩ or more) 4 - 20 mAdc (0 - 20 mAdc) (allowable load resistance: 500 Ω or less)
AM	Output	Multifunction programmable analog output. 0 - 20 mAdc output with default setting. With [F686: Terminal AM switching], meter option (0 - 1 mA), current (0 - 20 mA) output, and voltage (0 - 10 V) output can be switched.	
PLC	Output	When the slide switch [SW1] is set to the sink side or source side, it can be used as 24 Vdc power output.	24 Vdc-200 mA (200 mA in total with P24) Compliant with IEC61131-2
PLC	Input	When the slide switch [SW1] is set to the PLC side, it can be used as a common terminal for digital input terminal.	-
P24	Output	24 Vdc power output.	24 Vdc-200 mA (200 mA in total with PLC) Compliant with IEC61131-2
+SU	Input	DC power input to operate the control circuit. Connect a control power supply option or 24 Vdc power supply between [+SU] and [CC].	24 Vdc- current 1A or more
STOA	Input	At the time of shipping, the terminals [STOA]-[STOB]-[PLC] are shorted by the shorting bar. This is a terminal with STO function that complies with the safety standard IEC61800-5-2. For details, refer to Safety Function Manual. This terminal is not programmable digital input.	Refer to Safety Function Manual. Compliant with IEC61131-2 logic type 1 • Activate < 5 V, 11 V < Deactivate Not coast stop
STOB	Input		
FLA	Output	Multifunction programmable relay contact output. Operation of the protection function of the inverter is detected in the default setting. The contact across [FLA]-[FLC] is closed and [FLB]-[FLC] is opened during protection function operation.	Maximum contact capacity •250 Vac-2 A (cos φ=1) •30 Vdc-2 A (at resistive load) •250 Vac-1 A (cos φ=0.4) •30 Vdc-1A (L/R=7 ms)
FLB	Output		
FLC	Output		
R1A	Output	Multifunction programmable relay contact output. A low-speed signal is output in the default setting.	Minimum contact capacity •24 Vdc-5 mA
R1C	Output		
R2A	Output	Multifunction programmable relay contact output. It is not assigned in the default setting. The function can be set with [F134: Terminal R2 function].	Life •100000 times
R2C	Output		

For drive users

When studying how to use our drives

Notes

Leakage current

This drive uses high-speed switching devices for PWM control. When a relatively long cable is used for power supply to a drive, current may leak from the cable or the motor to the ground because of its capacitance, adversely affecting peripheral equipment. The intensity of such a leakage current depends on the PWM carrier frequency, the lengths of the input and output cables, etc., of the drive. To prevent current leakage, it is recommended to take the following measures.

[Effects of leakage current]

Leakage current which increases when a drive is used may pass through the following routes:

- Route (1) ... Leakage due to the capacitance between the ground and the noise filter
 - Route (2) ... Leakage due to the capacitance between the ground and the drive
 - Route (3) ... Leakage due to the capacitance between ground and the cable connecting the drive and the motor
 - Route (4) ... Leakage due to the capacitance of the cable connecting the motor and a drive in another power distribution line
 - Route (5) ... Leakage through the grounding line common to motors
 - Route (6) ... Leakage to another line because of the capacitance of the ground
- Leakage current which passes through the above routes may cause the following trouble.
- Malfunction of a earth leakage circuit breaker (ELCB) in the same or another power distribution line
 - Malfunction of a ground-relay installed in the same or another power distribution line
 - Noise produced at the output of an electronic device in another power distribution line
 - Activation of an external thermal relay installed between the drive and the motor, at a current below the rate current

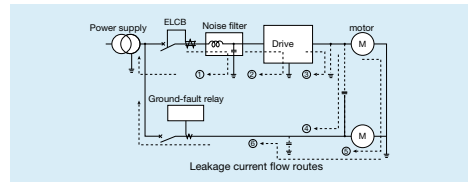

[Measures against effects of leakage current]

The measures against the effects of leakage current are as follows:

- 1) Measures to prevent the malfunction of ELCBs
 - (1) Decrease the PWM carrier frequency of the drive. ^(Note)
 - (2) Use radio-frequency interference-proof ELCBs as ground-fault interrupters in not only the system into which the drive is incorporated but also other systems. When ELCBs are used, the PWM carrier frequency needs to be increased to operate the drive.
 - (3) When connecting multiple drives to a single ELCB, use an ELCB with a high current sensitivity or reduce the number of drives connected to the ELCB.
- 2) Measures against malfunction of ground-fault relay: ^(Note)
 - (1) Decrease the PWM carrier frequency of the drive. ^(Note)
 - (2) Install ground-fault relays with a high-frequency protective function in both the same and other lines. When ELCBs are used, the PWM carrier frequency needs to be increased to operate the drive.
- 3) Measures against noise produced by other electric and electronic systems:
 - (1) Separate the grounding line of the drive from that of the affected electric and electronic systems.
 - (2) Decrease the PWM carrier frequency of the drive. ^(Note)
- 4) Measures against malfunction of external thermal relays:
 - (1) Remove the external thermal relay and use the electronic thermal function of the drive instead of it. (Unapplicable to cases where a single drive is used to drive more than one motor. Refer to the instruction manual for measures to be taken when thermal relays cannot be removed.)
 - (2) Decrease the PWM carrier frequency of the drive. ^(Note)
- 5) Measures by means of wiring and grounding
 - (1) Use a grounding wire as large as possible.
 - (2) Separate the drive's grounding wire from that of other systems or install the grounding wire of each system separately to the grounding point.
 - (3) Ground (shield) the power circuit wires with metallic conduits.
 - (4) Use the shortest possible wires to connect the drive to the motor.

- (5) If the drive has a high-attenuation EMC filter, turn off the grounding capacitor detachment switch to reduce the leakage current. Note that doing so leads to a reduction in the noise attenuating effect.

Note) In the case of this drive, the PWM carrier frequency can be decreased to 1.0kHz. However, that it should not be set to less than 2.0kHz during vector control. Decreasing the carrier frequency results in an increase in electromagnetic noise from the motor.

Ground fault

Before beginning operation, thoroughly check the wiring between the motor and the drive for incorrect wiring or short circuits. Do not ground the neutral point of any star-connected motor.

Radio interference

[Noise produced by drives]

Since this drive performs PWM control, it produces noise and sometimes affects nearby instrumental devices, electrical and electronic systems, etc. The effects of noise greatly vary with the noise resistance of each individual device, its wiring condition, the distance between it and the drive, etc.

[Measures against noises]

According to the route through which noise is transmitted, the noises produced by a drive are classified into transmission noise, induction noise and radiation noise.

[Examples of protective measures]

- Separate the power line from other lines, such as weak-current lines and signal lines, and install them apart from each other.
- Install a noise filter in each drive. It is effective for noise prevention to install noise filters in other devices and systems, as well.
- Shield cables and wires with grounded metallic conduits, and cover electronic systems with grounded metallic cases.
- Separate the power distribution line of the drive from that of other devices and systems.
- Install the input and output wires of the drive apart from each other.
- Use shielded twisted pair wires for wiring of the weak-current and signal circuits, and always ground one of each pair of wires.
- Ground the drive with grounding wires as large and short as possible, separately from other devices and systems.

On 480V models, noise can be greatly reduced as they have a built-in EMC noise filter on their input side.

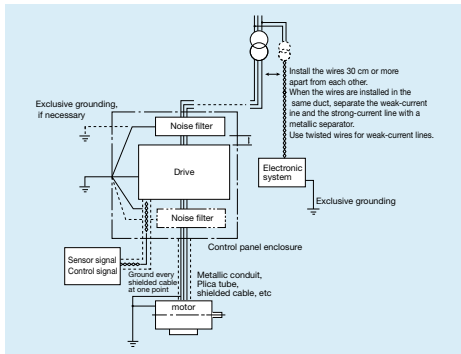

Power factor improvement capacitors

Do not install a power factor improvement capacitors on the input or output side of the drive.

Installing a power factor improvement capacitor on the input or output side causes current containing harmonic components to flow into the capacitor, adversely affecting the capacitor itself or causing the drive to trip. To improve the power factor, install an input AC reactor on the primary side of the drive.

Installation of input AC reactors

These devices are used to improve the input power factor and suppress high harmonic currents and surges. Install an input AC reactor when using this drive under the following conditions:

- (1) When the power supply capacity is 500kVA or more, and when it is 10 times or more greater than the drive capacity.
- (2) When the drive is connected the same power distribution system as a thyristor-committed control equipment.
- (3) When the drive is connected to the same power distribution system as that of distorted wave-producing systems, such as arc furnaces and large-capacity drives.

When wiring the drive

Wiring precautions

Installing a molded-case circuit breaker [MCCB]

- (1) Install ELCB or MCCB with an electric leak detector on the drive's power supply input to protect the wiring.
- (2) Avoid turning the ELCB or MCCB on and off frequently to turn on/off the motor.
- (3) To turn on/off the motor frequently, ON/OFF the control terminals F (or R)-CC.

Installing a magnetic contactor [MC] [primary side]

- (1) To prevent an automatic restart after the power interruption or overload relay has tripped, or actuation of the protective circuit, install a magnetic contactor in the power supply.
- (2) The drive is provided with a failure detection relay (FL), so that, if its contacts are connected to the operation circuit of the magnetic contactor on the primary side, the magnetic contactor will be opened when the protective circuit of the drive is activated.
- (3) The drive can be used without a magnetic contactor. In this case, use an MCCB (equipped with a voltage tripping device) for opening the primary circuit when the drive protective circuit is activated.
- (4) Avoid turning the magnetic contactor on and off frequently to turn on/off the motor.
- (5) To turn on/off the motor frequently, ON/OFF the control terminals F (or R)-CC.

Installing a magnetic contactor [MC] [secondary side]

- (1) As a rule, if a magnetic contactor is installed between the drive and the motor, do not turn of ON/OFF while running. (If the secondary-side contactor is turned of ON/OFF while running, a large current may flow in the drive, causing drive damage and failure.)
- (2) A magnetic contactor may be installed to change the motor or change to the commercial power supply when the drive is stopped. Always use an interlock with the magnetic contactor in this situation so that the commercial power supply is not applied to the drive's output terminals.

External signal

- (1) Use a relay rated for low currents. Mount a surge absorber on the excitation coil of the relay.
- (2) When wiring the control circuit, use shielded wires or twisted pair cables.
- (3) Because all of the control terminals except FLA, FLB, FLC, R1A, R1B, R2A and R2B are connected to electronic circuits, insulate these terminals to prevent them from coming into contact with the power circuit.

Installing an overload relay

- (1) The drive has an electronic-thermal overload protective function. However, in the following cases, the thermal relay operation level must be adjusted or an overload relay matching the motor's characteristics must be installed between the drive and the motor.
 - (a) When operating a motor that is smaller than applied motor capacity.
 - (b) When driving several motors simultaneously.
- (2) When using the drive to control the operation of a constant-torque motor, change the protective characteristic of the electronic thermal relay according to the setting of constant torque motor.
- (3) In order to adequately protect a motor used for low-speed operation, we recommend the use of a motor equipped with an embedded thermal relay.

When changing the motor speed

Application to standard motors

Vibration

When a motor is operated with an industrial drive, it experiences more vibrations than when it is operated by the commercial power supply. The vibration can be reduced to a negligible level by securing the motor and machine to the base firmly. If the base is weak, however, the vibration may increase at a light load due to resonance with the mechanical system.

Reduction gear, belt, chain

Note that the lubrication capability of a reducer or a converter used as the interface of the motor and the load machine may be affected at low speeds. When operating at a frequencies over 60 Hz, power transmission mechanisms such as reduction gear, belts and chains, may cause problems such as production of noise, a reduction in strength, or shortening of service life.

Frequency

Before setting the maximum frequency to 60 Hz or more, confirm that this operating range is acceptable for the motor.

Application to special motors

Braking motor

When using a braking motor, if the braking circuit is directly connected to the drive's output terminals, the brake cannot be released because of the lowered starting voltage. Therefore, when using a braking motor, connect the braking circuit to the drive's power supply side, as shown on the below. Usually, braking motors produce larger noise in low speed ranges.

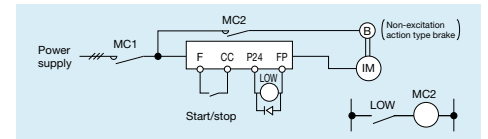

Gear motor

When using an industrial drive to drive a gear motor, inquire of the motor manufacturer about its continuous operation range, since low-speed operation of a gear motor may cause insufficient lubrication.

Toshiba Premium Gold Motor (High-efficiency power-saving motor)

Drive operation of Toshiba Premium Gold Motor is the best solution for saving energy. This is because these motors have improved efficiency, power factor, and noise/vibration reduction characteristics when compared to standard motors.

Pole-changing motor

Pole-changing motors can be driven by this drive. Before changing poles, however, be sure to let the motor come to a complete stop.

High-pole-count motors

Note that high-pole count motors(8 or more poles), which may be used for fans, etc., have higher rated current than 4-pole motors. The current ratings of multipole motors are relatively high. So, when selecting a drive, you must pay special attention to its current rating so that the current rating of the motor is below that of the drive.

Single-phase motor

Because single-phase motors are equipped with a centrifugal switch and capacitors for starting, they cannot be driven by a drive.

Peripheral devices

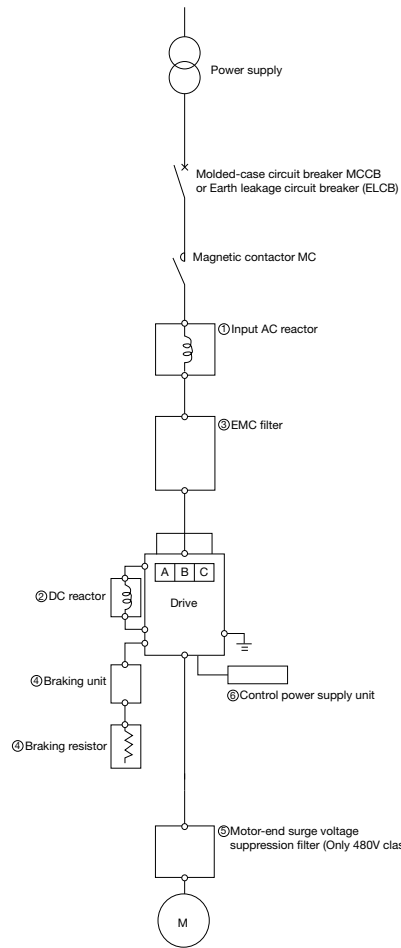

Insert type options

Slot	Name	Function/Purpose, etc	Refer to
A,B,C	I/O extension 1	This option is convenient for adding on I/O terminals.(Type:ETB013Z)	24
A,B,C	I/O extension 2	This option is convenient for adding on I/O terminals.(Type:ETB014Z)	
B	Digital encoder	Closed loop operation is possible by combining with a motor equipped with a sensor.(Type:VEC008Z)	
B	Resolver	Closed loop operation is possible by combining with a motor equipped with a sensor.(Type:VEC010Z)	
C	Safety option	This option enables adding on more safety functions. (Type:SF7001Z)	
A	PROFINET	This option enables PROFINET connectivity with a host controller or other PLC. (Type:PNE001Z)	
A	PROFIBUS-DP	This option enables PROFIBUS-DP connectivity with a host controller or other PLC. (Type:PDP003Z)	
A	DeviceNet	This option enables DeviceNet connectivity with a host controller or other PLC. (Type:DEV003Z)	
A	EtherCAT	This option enables EtherCAT connectivity with a host controller or other PLC. (Type:IPE003Z)	
A	CANopen	This option enables CANopen connectivity with a host controller or other PLC. (Type:CAN001Z,CAN002Z,CAN003Z)	

External options

No.	Name	Function/Purpose, etc	Refer to
①	Input AC reactor	Input AC reactor is used for improving input power factor on the drive power side (primary side), reducing harmonics or restriction of surge voltage. It is also installed when the power supply capacity is 500 kVA or more and is 10 times or more of the drive capacity, and when devices that cause distorted waves (a device with thyristor, etc.) and a large capacity drive is connected on the same power distribution line. Install an input AC reactor between the power supply and the drive (primary side).	26
②	DC reactor	A DC reactor is a reactor to connect with the DC terminal, and used for improving input power factor and reducing harmonics. It has better power factor improvement effect than an input AC reactor. When a facility applying the drive requires high reliability, it is recommended to use with an input AC reactor that has surge voltage restriction effect. However, the frame size A1 to A6 of the drive has a built-in DC reactor as standard, and the frame size A7 and A8 attached with a DC reactor, no option is available.	-
③	EMC filter	When installing an EMC filter and wire properly, it can comply with EMC Directive. 480 V model of the drive has the built-in EMC filter as standard; however, if an EMC filter is added externally, noise reduction becomes more effective. Please contact your Toshiba distributor for details.	-
④	Braking resistor	It is a resistor to consume regenerative energy from a motor. When making frequent rapid deceleration and stop, it is used to shorten deceleration time with load in large inertia. A braking unit is necessary in addition to a braking resistor for the frame size A6 and A8.	28 to 30
⑤	Motor-end surge voltage suppression filter (Only 480V class)	When operating a 480 V class general purpose motor with a voltage type PWM control drive that uses high speed switching element (IGBT, etc.), surge voltage exceeding the insulation level of motor winding is generated depending on power supply voltage, motor wire length and its laying method, and type. When the condition is repeatedly applied for a long time, it may cause deterioration of insulation on the motor. Such measures as installation of an AC reactor, surge voltage suppression filter, sinusoidal filter on the drive output side (secondary side), and use of a high insulation strength motor are necessary.	27
⑥	Control power supply unit	Control power need not be input separately as it is supplied internally on the drive from the power circuit power supply. Use this option when backing up only by the control power supply when the power circuit is shut off. This is +24 VDC output common to both 240 and 480 V models. (Type : CPS002Z)	33
⑦	USB communications conversion unit	It enables to set and manage parameters on a personal computer. Connect between the RS-485 communication connector 2 of the drive and a personal computer. Use the specific cable for the drive side, and a commercial USB cable (USB 1.1/2.0 compatible A-B connection type) for a personal computer side. Software PCM002Z for parameter management is required. (Type: USB001Z, Specific cable Type: CAB0011 (1 m), CAB0013 (3 m), CAB0015 (5 m))	32
⑧	Door mounting kit for Operation panel	The operation panel can be mounted on a cabinet surface by means of a door mounting kit. (Type:SBP010Z, Specific cable Type:CAB0071 (1 m), CAB0073 (3 m), CAB0075 (5 m), CAB00710 (10 m))	32
⑨	LED extension panel	It is an extension panel for LED display. A specific cable is used to connect between the drive and LED panel. (Type: RKP002Z, Specific cable Type: CAB0011 (1 m), CAB0013 (3 m), CAB0015 (5 m); Type: RKP007Z, Specific cable Type: CAB0071 (1 m), CAB0073 (3 m), CAB0075 (5 m))	32
⑩	Flange mounting kit	This allows heat generated inside panels to be reduced.	31
⑪	Operation panel	Has a built-in frequency type, frequency setter and RUN-STOP (forward run, reverse run) switch. (Type: GSVR-751)	33

Notes1) Ethernet cable: LAN cable comply with ANSI/TIA/EIA-568-B.2 (CAT5E or successor)
 Note2) A lithium battery for internal real time clock of the operation panel (equipped as standard at the time of shipping; CR2032EC/Toshiba)

Harmonic current and influence to power supply

Harmonics are defined as sinusoidal waves that is multiple frequency of commercial power supply (base frequency: 50Hz or 60Hz). Commercial power supply including harmonics has a distorted waveform. Some electrical and electronic devices produce distorted waves in their rectifying and smoothing circuits on the input side. Harmonics produced by a device influence other electrical equipment and facilities in some cases (for example, overheating of phase advancing capacitors and reactors).

Measures for suppressing higher harmonics

No.	Measures	Description
1	Connecting a reactor	The leakage of a harmonic current from a drive can be restricted by connecting an input AC reactor (ACL) on the input side of the drive or a DC reactor (DCR) to the DC section of the drive.
2	Connecting a higher harmonic suppressing unit	A PWM converter that shapes the waveform of an input current into a substantially sinusoidal waveform. The leakage of a harmonic current from a power supply can be restricted by connecting a harmonic suppressing unit.
3	Connecting a higher harmonic suppressing phase advancing capacitor	A harmonic current can be absorbed by the use of a phase advancing capacitor unit composed of a phase advancing capacitor and a DC reactor.
4	Multi-pulse operation of transformation	For delta-delta connection and delta-Y connection transformers, the effect of 12 pulses can be obtained by distributing the load evenly, and thus currents containing fifth-order and seventh-order harmonics can be suppressed.
5	Other measures	Harmonic currents can also be suppressed by the use of passive (AC) and active filters.

Insert type options

This drive is equipped with two optin slots (A, B) as standard. The option adaptor (option) can be mounted.

Table of optional devices

Name	Specification	Type-form	Slot availability
I/O extension 1	6x digital input 2x digital output 2x analog input	ETB013Z	A, B, C
I/O extension 2	3x 1a relay	ETB014Z	A, B, C
Digital encoder	RS422 Line receiver	VEC008Z	B
Resolver	Resolver	VEC010Z	B
Safety option	SS1, SS2, SOS, SBC, SLS, SDI	SFT001Z	C
PROFINET	PROFINET interface	PNE001Z	A
EtherCAT	EtherCAT interface	IPE003Z	A
PROFIBUS-DP	PROFIBUS-DP interface	PDP003Z	A
DeviceNet	DeviceNet interface	DEV003Z	A
CANopen	CANopen interface : RJ45 : D-sub : Open style	CAN001Z CAN002Z CAN003Z	A

Function of I/O extension

Type-form	ETB013Z	ETB014Z
Multifunction programmable contact input	Multifunction programmable contact input : 6 points Logic type selected by DICC wiring. Sink logic:ON<10V, 16V<OFF Source logic:OFF<5V, 11V<ON	Disable
Multifunction programmable open collector output	Multifunction programmable open collector output : 2 points Logic Type selected by DQCC wiring Max. switching voltage<= 30V Max. switching current<= 100mA Voltage drop at 100mA load <= 3V	Disable
Multifunction programmable relay contact output	Disable	Multifunction programmable relay contact output: 3 relay(1a) 250 Vac-2A(cosφ=1), 30 Vdc-2A (at resistive load) 250 Vac-1A(cosφ=0.4), 30 Vdc-1A (LR=7 ms)
Analog input	Differential analog input: 2 points Voltage input: -10Vdc to +10Vdc Impedance: 20kohm Current input: 0 to 20mA Impedance: 250ohm	Disable

Function sensor feedback

Type-form	VEC008Z	VEC010Z
Sensor type	Incremental rotary encoder	Resolver
Specification	Signal interface: differential line driver (TIA/EIA RS422) Pulse frequency: 300kHz or less (Duty: 50% ±10%) Maximum load of power supply for encoder: 24V 100mA, 12V 100mA, 5V 250mA	Signal interface:Ref+, Cos-, Sin+, Cos+, Sin-, Ref- Excitation Carrier:3 to 12kHz Pole pairs number = 1 Transformation ratio = 0.5 Reference (Excitation voltage): 7Vrms
Connector	D subminiature connector (DE-15 / HD15)	D subminiature connector (DE-9)

How to install

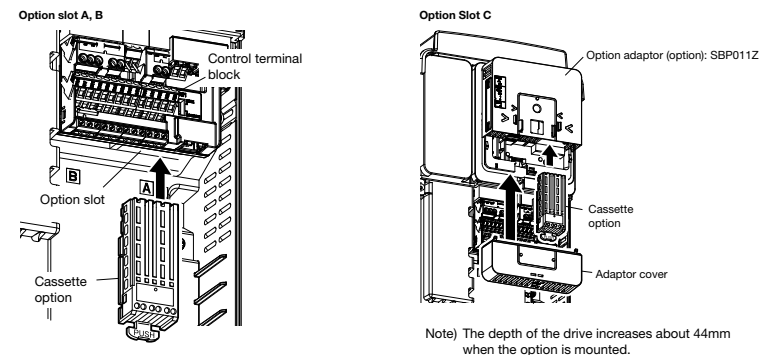

Note) The depth of the drive increases about 44mm when the option is mounted.

Motor end surge voltage suppression filter (Only 480V class)

External dimensions

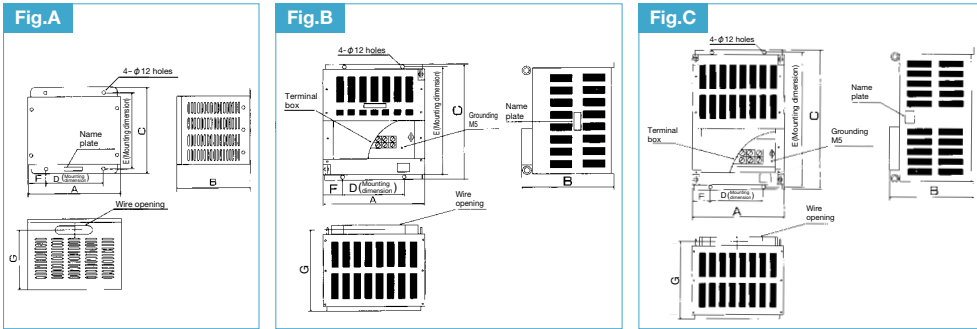

Connection diagram

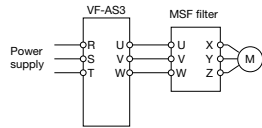

Countermeasure of motor end surge voltage

At the system of operation of the 480V class motor by the voltage type PWM drive with using super high-speed switching device(ex.IGBT), the degradation of insulation of motor winding may be occurred by the length conditions of the cable, laid down of the cable and the constants of the cable. In this case, the following countermeasures are suggested.

- 1) Use of the enhanced insulation type of motor
 - 2) Suppress the surge voltage by AC reactors in the load side or surge suppression filter.
- Note 1) To be installed floor horizontal mounting.
Note 2) To be used that carrier frequency is 15kHz or less, and output frequency is 60Hz or less.

Model	Drive type-form	Dimensions (mm)							External dimension diagram	Terminal screw	Approx. mass (kg)
		A	B	C	D	E	F	G			
MSF-4015Z	VFAS3-4004PC(HD) to VFAS3-4015PC(HD) VFAS3-4004PC(ND), 4007PC(ND)	310	255	300	200	270	55	189	A	M4	12
MSF-4037Z	VFAS3-4022PC(HD), 4037PC(HD) VFAS3-4015PC(ND), 4022PC(ND)	310	255	300	200	270	55	209		M4	20
MSF-4075Z	VFAS3-4055PC(HD), 4075PC(HD) VFAS3-4037PC(ND), 4055PC(ND)	310	315	350	200	320	55	249		M5	30
MSF-4150Z	VFAS3-4110PC(HD), 4150PC(HD) VFAS3-4075PC(ND), 4110PC(ND)	330	350	400	200	370	65	289	B	M6	40
MSF-4220Z	VFAS3-4185PC(HD), 4220PC(HD) VFAS3-4150PC(ND), 4185PC(ND)	330	400	400	200	370	65	279		M6	52
MSF-4370Z	VFAS3-4300PC(HD), 4370PC(HD) VFAS3-4220PC(ND), 4300PC(ND)	426	375	512	260	490	83	350		M8	75
MSF-4550Z	VFAS3-4450PC(HD), 4550PC(HD) VFAS3-4370PC(ND), 4450PC(ND)	450	395	632	260	610	95	365	C	M10	110
MSF-4750Z	VFAS3-4750PC(HD) VFAS3-4550PC(ND)	450	415	700	260	678	95	385		M10	120

External dimensions

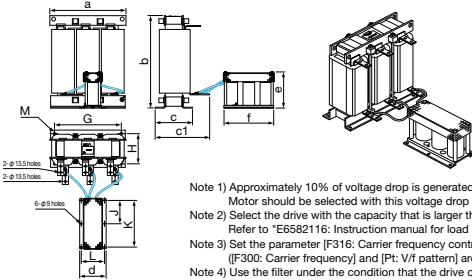

- Note 1) Approximately 10% of voltage drop is generated by the filter, depending on the output current and the motor power factor. Motor should be selected with this voltage drop in consideration.
- Note 2) Select the drive with the capacity that is larger than the motor, due to the carrier frequency limitation of the filter and the current reduction of the drive. Refer to "E6582116: Instruction manual for load reduction" for detail of current reduction.
- Note 3) Set the parameter [F316: Carrier frequency control] to "4" or "5" (sinusoidal filter usage). ([F300: Carrier frequency] and [P: V/f pattern] are limited, refer to Instruction manual for detail.)
- Note 4) Use the filter under the condition that the drive output frequency is 100Hz or less and the ambient temperature is -10 to 50°C.

Connection diagram

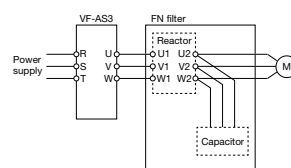

Applicable Motor (kW) Note 1)	Drive type-form Note 2)		Model Note 4)	Dimensions (mm)													Approx. mass (kg)	
	HD rating	ND rating		a	b	c	c1	G	H	M	d	e	f	J	K	L		
90	VFAS3-4110KPC	VFAS3-4900PC	FN5040-410-99	490	600	240	355	430	194	10.6x18.6	170	240	328	150	300	150	177	
110	VFAS3-4132KPC	VFAS3-4110KPC																
132	VFAS3-4160KPC	VFAS3-4132KPC																
160	VFAS3-4200KPC	VFAS3-4160KPC																
200	VFAS3-4220KPC	VFAS3-4160KPC	FN5040-480-99	510	618	270	410	430	195	13x27	270	220	328	150	300	250	220	
220	VFAS3-4280KPC	VFAS3-4200KPC																
250	-	VFAS3-4220KPC	FN5040-750-99	660	670	290	468	570	220	13x26	375	200	555	255	510	350	455	
280	-	VFAS3-4280KPC																

Braking resistor

Braking resistor (PBR)

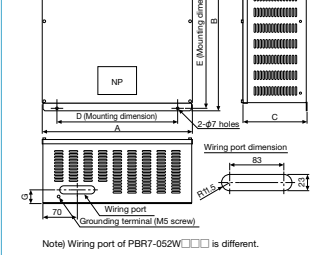
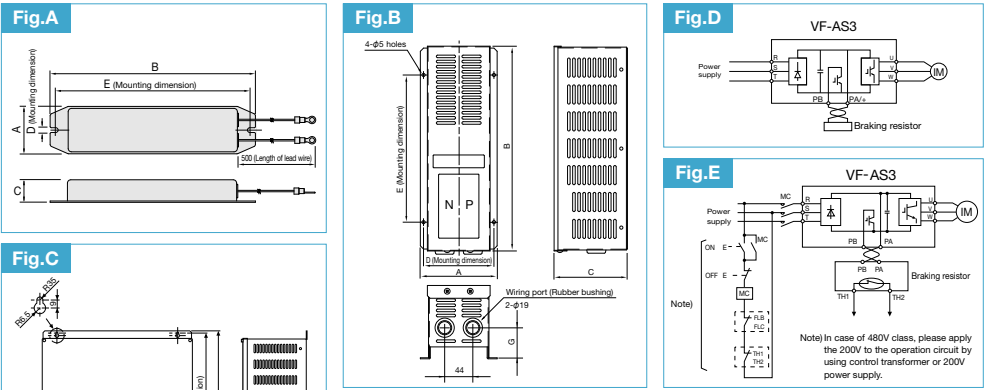

Type	Model	Dimensions (mm)						Approx. mass (kg)	External dimension diagram	Connection diagram
		A	B	C	D	E	G			
Standard	PBR-2007	42	182	20	4.2	172	-	0.28	A	D
	PBR-2022									
	PBR-2037									
	PBR-4037									
400W class	PBR7-004W □□□	120	320	115	110	230	48	3.4	B	E
1.5kW class	PBR7-017W □□□	240	430	190	190	414	52	10		
5kW class	PBR7-052W □□□	395	616	190	320	600	52	29		

- Note 1) □□□ in the type-form are numeric character. Please refer to the "Selection of braking resistor" in the next page.
- Note 2) The rating shows the synthetic resistor value (Ohm) and the synthetic resistor power (Watt). The word in the parentheses shows the composition of resistor elements.
- Note 3) The allowable continuous regenerative power differs on the resistor value or power tolerance. Please refer the "Selection of braking resistor" in the next page.

Braking resistor (DGP600)

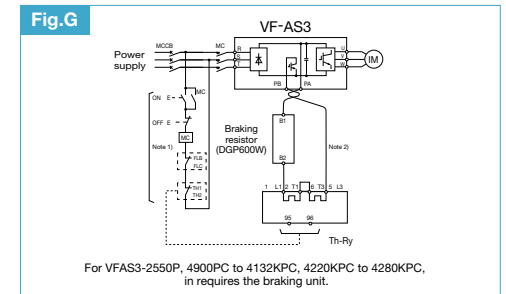
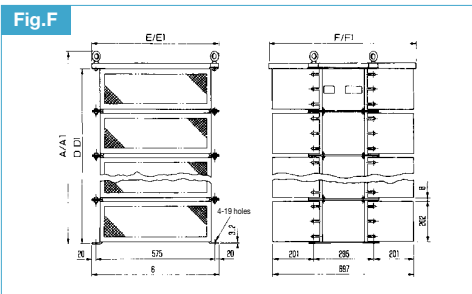

- Note 1) In case of 480 V class, please apply the 200V to the operation circuit by using control transformer or 200V power supply.
- Note 2) Please twist the wire by 10 cm pitch. The distance between resistor power wiring and the control wiring should be over 20 cm.
- Note 3) Please make a short circuit between the 2/T1 and 6/T3 of the thermal relay.

Standard	Model	Rating	Dimensions (mm) Note 2)				External dimension diagram	Connection diagram	Thermal relay (Th-Ry) Setting value (A)	Approx. mass (kg)
			A/A1	D/D1	E/E1	F/F1				
DGP600W-B1	DGP600W-C1	1.70-3.4kW	283/303	207/192	620/700	725/780	F	G	46	50
DGP600W-B2	DGP600W-C2	3.70-7.4kW	493/513	417/402	620/700	725/780			44	100
DGP600W-B3	DGP600W-C3	1.90-8.7kW	703/723	627/612	620/700	725/780			71	150
		2.50-10.5kW							65	150
DGP600W-B4	DGP600W-C4	50-10kW	913/933	837/822	620/700	725/780	45	150		
		1.40-14kW					110	200		
		1.70-10kW					77	200		

- Note 1) The braking resistors are designed for indoor type. Please use them with drip cover in case of water drop. But please note it is not for water proof protection type.
- Note 2) A,D,E,F are the dimensions of standard type. A1,D1,E1,F1 are the dimensions of those with drip cover type.

Selection of braking resistor

This is used for the quick deceleration, the frequent deceleration stop or shortening the deceleration time at the large inertia load. This resistor consumes the regenerative energy when regenerative braking operation. In case of over 3% ED, please select the allowable continuous regenerative power (Watt) in the following table.
 1) The continuous regenerative load like an elevator
 2) Deceleration stops at large inertia machine
 3) Frequent deceleration stop by using braking resistors

HD rating

Voltage class	Applicable motor (kW)	Drive type-form	Minimum allowable resistance (Ω)	Model						
				PBR	DGP600	High frequency type				
						800W class	1.5kW class	3.5kW class	5kW class	10kW class
240V	0.4	VFAS3-2004P	7.9	PBR-2007 (90W-200Ω)	-	-	-	-	-	-
	0.75	VFAS3-2007P	7.9	-	-	-	-	-	-	-
	1.5	VFAS3-2015P	7.9	PBR-2022 (90W-75Ω)	-	-	-	-	-	-
	2.2	VFAS3-2022P	7.9	-	-	-	-	-	-	-
	4.0	VFAS3-2037P	7.9	PBR-2037 (90W-40Ω)	-	-	-	-	-	-
	5.5	VFAS3-2055P	5.3	PBR7-004W015 (130W-15Ω)	-	-	-	-	-	-
	7.5	VFAS3-2075P	5.3	-	-	-	-	-	-	-
	11	VFAS3-2110P	5	-	-	-	-	-	-	-
	15	VFAS3-2150P	5	-	-	-	-	-	-	-
	18.5	VFAS3-2185P	4.5	-	-	-	-	-	-	-
	22	VFAS3-2220P	1	PBR7-017W3R7 (540W-3.75Ω)	-	-	-	-	-	-
	30	VFAS3-2300P	1	-	-	-	-	-	-	-
	37	VFAS3-2370P	1	-	-	-	-	-	-	-
	45	VFAS3-2450P	1	PBR7-035W1R8 (1080W-1.87Ω)	-	-	-	-	-	-
55	VFAS3-2550P	1	-	-	-	-	-	-	-	
480V	0.4	VFAS3-4004PC	7.8	-	-	-	-	-	-	-
	0.75	VFAS3-4007PC	7.8	PBR-2007 (90W-200Ω)	-	-	-	-	-	-
	1.5	VFAS3-4015PC	7.8	-	-	-	-	-	-	-
	2.2	VFAS3-4022PC	31.2	-	-	-	-	-	-	-
	4.0	VFAS3-4037PC	31.2	PBR-4037 (90W-160Ω)	-	-	-	-	-	-
	5.5	VFAS3-4055PC	22.3	PBR7-004W060 (130W-60Ω)	-	-	-	-	-	-
	7.5	VFAS3-4075PC	22.3	-	-	-	-	-	-	-
	11	VFAS3-4110PC	15.6	-	-	-	-	-	-	-
	15	VFAS3-4150PC	15.6	PBR7-008W030 (270W-30Ω)	-	-	-	-	-	-
	18.5	VFAS3-4185PC	15.6	-	-	-	-	-	-	-
	22	VFAS3-4220PC	12	PBR7-017W015 (540W-15Ω)	-	-	-	-	-	-
	30	VFAS3-4300PC	12	-	-	-	-	-	-	-
	37	VFAS3-4370PC	7.9	PBR7-017W010 (540W-10Ω)	-	-	-	-	-	-
	45	VFAS3-4450PC	2.5	PBR7-017W7R5 (540W-7.5Ω)	-	-	-	-	-	-
55	VFAS3-4550PC	2.5	-	-	-	-	-	-	-	
75	VFAS3-4750PC	2.5	PBR7-017W3R7 (540W-3.75Ω)	-	-	-	-	-	-	
90	VFAS3-4900PC	1.9	-	-	-	-	-	-	-	
110	VFAS3-4110KPC	1.9	-	-	-	-	-	-	-	
132	VFAS3-4132KPC	1.9	-	-	-	-	-	-	-	
160	VFAS3-4160KPC	1.9	-	-	-	-	-	-	-	
200	VFAS3-4200KPC	1	-	-	-	-	-	-	-	
220	VFAS3-4220KPC	1	-	-	-	-	-	-	-	
280	VFAS3-4280KPC	1	-	-	-	-	-	-	-	

ND rating

Voltage class	Applicable motor (kW)	Drive type-form	Minimum allowable resistance (Ω)	Model						
				PBR	DGP600	High frequency type				
						800W class	1.5kW class	3.5kW class	5kW class	10kW class
240V	0.75	VFAS3-2004P	7.9	PBR-2007 (90W-200Ω)	-	-	-	-	-	-
	1.5	VFAS3-2007P	7.9	PBR-2022 (90W-75Ω)	-	-	-	-	-	-
	2.2	VFAS3-2015P	7.9	-	-	-	-	-	-	-
	4.0	VFAS3-2022P	7.9	PBR-2037 (90W-40Ω)	-	-	-	-	-	-
	5.5	VFAS3-2037P	7.9	PBR7-004W015 (130W-15Ω)	-	-	-	-	-	-
	7.5	VFAS3-2055P	5.3	-	-	-	-	-	-	-
	11	VFAS3-2075P	5.3	-	-	-	-	-	-	-
	15	VFAS3-210P	5	PBR7-008W7R5 (270W-7.5Ω)	-	-	-	-	-	-
	18.5	VFAS3-2150P	5	-	-	-	-	-	-	-
	22	VFAS3-2185P	4.5	-	-	-	-	-	-	-
	30	VFAS3-2220P	1	PBR7-017W3R7 (540W-3.75Ω)	-	-	-	-	-	-
	37	VFAS3-2300P	1	-	-	-	-	-	-	-
	45	VFAS3-2370P	1	-	-	-	-	-	-	-
	55	VFAS3-2450P	1	PBR7-035W1R8 (1080W-1.87Ω)	-	-	-	-	-	-
75	VFAS3-2550P	1	-	-	-	-	-	-	-	
480V	0.75	VFAS3-4004PC	7.8	PBR-2007 (90W-200Ω)	-	-	-	-	-	-
	1.5	VFAS3-4007PC	7.8	-	-	-	-	-	-	-
	2.2	VFAS3-4015PC	7.8	-	-	-	-	-	-	-
	4.0	VFAS3-4022PC	31.2	-	-	-	-	-	-	-
	5.5	VFAS3-4037PC	31.2	PBR-4037 (90W-160Ω)	-	-	-	-	-	-
	7.5	VFAS3-4055PC	22.3	PBR7-004W060 (130W-60Ω)	-	-	-	-	-	-
	11	VFAS3-4075PC	22.3	-	-	-	-	-	-	-
	15	VFAS3-4110PC	15.6	PBR7-008W030 (270W-30Ω)	-	-	-	-	-	-
	18.5	VFAS3-4150PC	15.6	-	-	-	-	-	-	-
	22	VFAS3-4185PC	15.6	-	-	-	-	-	-	-
	30	VFAS3-4220PC	12	PBR7-017W015 (540W-15Ω)	-	-	-	-	-	-
	37	VFAS3-4300PC	12	-	-	-	-	-	-	-
	45	VFAS3-4370PC	7.9	PBR7-017W010 (540W-10Ω)	-	-	-	-	-	-
	55	VFAS3-4450PC	2.5	PBR7-017W7R5 (540W-7.5Ω)	-	-	-	-	-	-
75	VFAS3-4550PC	2.5	PBR7-017W3R7 (540W-3.75Ω)	-	-	-	-	-	-	
90	VFAS3-4750PC	2.5	-	-	-	-	-	-	-	
110	VFAS3-4900PC	1.9	-	-	-	-	-	-	-	
132	VFAS3-4110KPC	1.9	-	-	-	-	-	-	-	
160	VFAS3-4132KPC	1.9	-	-	-	-	-	-	-	
220	VFAS3-4160KPC	1.9	-	-	-	-	-	-	-	
250	VFAS3-4200KPC	1	-	-	-	-	-	-	-	
280	VFAS3-4220KPC	1	-	-	-	-	-	-	-	
315	VFAS3-4280KPC	1	-	-	-	-	-	-	-	

Note 1) For VFAS3-2550P, 4900PC, 4132KPC, 4220KPC to 4280KPC, it requires the braking unit.
 Note 2) The figures in the parentheses show the synthetic resistor value (Ohm) and the allowable continuous regenerative power (Watt).
 Note 3) The guideline of the maximum braking at the standard type.
 Note 4) The necessary power in case of deceleration from 60Hz at one time per 120 seconds periods at 30 seconds deceleration time for the 10 times of the motor inertia, please contact our agency when large inertia or quick deceleration.
 Note 5) The braking resistors are designed for indoor type. Please use them with drip cover in case of water drop. But please note it is not for water proof protection type.

Braking unit

Specification	PB7-4132K	PB7-4200K	
Threshold voltage	240V class 480V class	379V 758V	- 758V
Maximum DC voltage	820V 825V		
Maximum braking power	240V class 480V class	93kW 220kW	- 420kW

External dimensions

PB7-4132K is mechanically mounted on the bottom side of the drive.
 Approx. mass 23kg

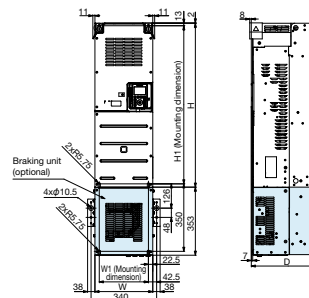

PB7-4200K is mechanically mounted on the left-hand side of the drive.
 Approx. mass 30kg

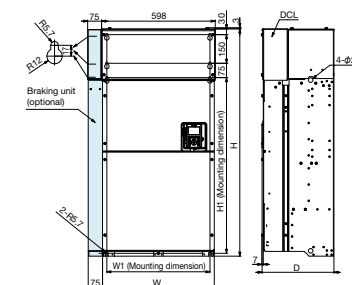

Flange mounting kit

This options enable the heatsink parts of the backside of drive that generate much heat to be located at the outside of the panel. This is effective for the small sizing of the totally-enclosed box by reducing the heat values inside the box.

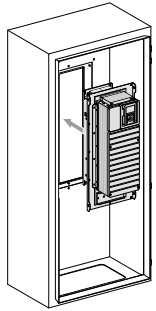

Model	Drive type-form	External dimension diagram	Approx. mass (kg)
FOT018Z	VFAS3-2004P to VFAS3-2022P VFAS3-4004PC to VFAS3-4037PC	A	1.3
FOT019Z	VFAS3-2037P VFA3-4055PC, 4075PC	B	1.5
FOT020Z	VFAS3-2055P, 2075P VFAS3-4110PC to VFA3-4185PC	C	1.9
FOT021Z	VFAS3-2110P to VFAS3-2185P VFAS3-4220PC to VFAS3-4370PC	D	6.8
FOT022Z	VFAS3-2220P to VFAS3-2370P VFAS3-4450PC to VFAS3-4750PC	E	9.4
FOT023Z	VFAS3-2450P, 2550P VFAS3-4900PC to 4132KPC	F	15.5
FOT013Z	VFAS3-4160KPC	G	4.4
FOT014Z	VFAS3-4200KPC to VFAS3-4280KPC	H	4.7
FOT015Z	VFAS3-4200KPC to VFAS3-4280KPC with using PB7-4200K	H	4.9

Fig.A

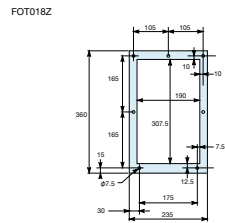

Fig.B

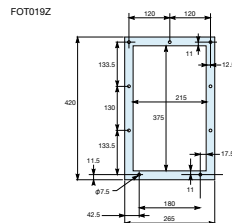

Fig.C

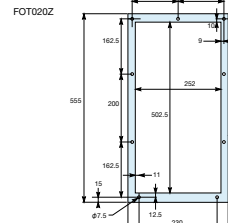

Fig.D

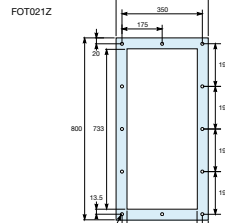

Fig.E

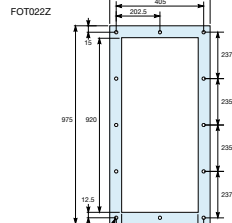

Fig.F

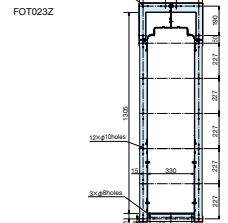

Fig.G

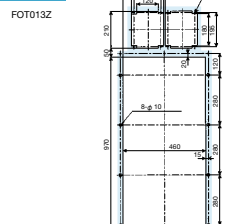
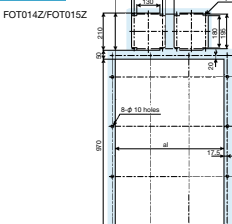

Fig.H



Model	Dimensions (mm)			
	D1	a1	G	G1
FOT014Z	90	610	645	215
FOT015Z	165	685	720	240

Door mounting kit

Type-form: SBP010Z

Mounting on the cabinet

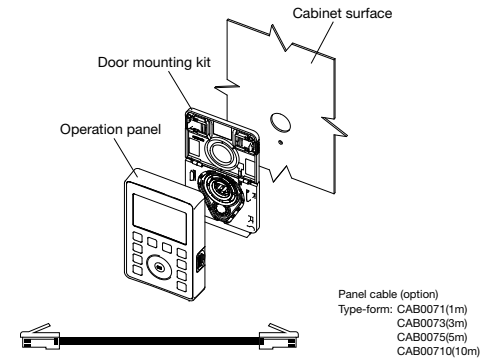

Note) Operation panel juts out about 26mm from the cabinet surface when the option is mounted on the cabinet surface.

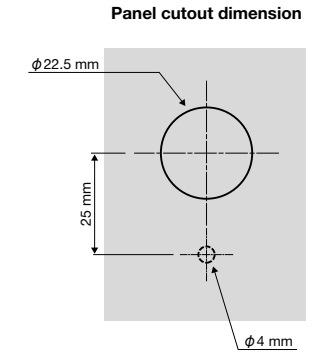

LED Extension panel

Type-form: RKP002Z (It has parameter copy function)

Dimension

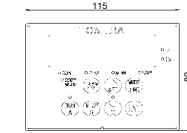

Panel cutout dimension

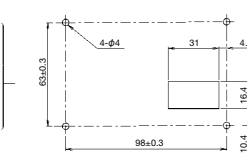

Unit: mm
Approx mass: 0.11kg

Type-form: RKP007Z

Dimension

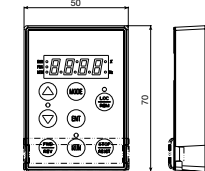

Panel cutout dimension

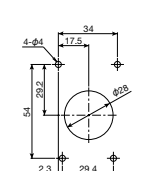

Unit: mm
Approx mass: 39g

Communication cable Type-form: CAB0011 (1m), CAB0013 (3m), CAB0015 (5m)

Communication cable Type-form: CAB0071 (1m), CAB0073 (3m), CAB0075 (5m)

USB communication conversion unit

Type-form: USB012Z

Drive can be management and setting on a PC

Connection

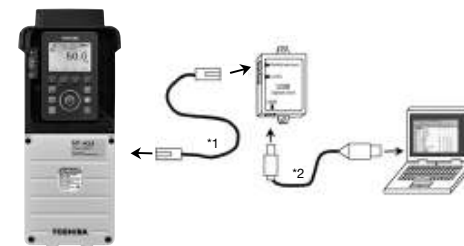

Dimension

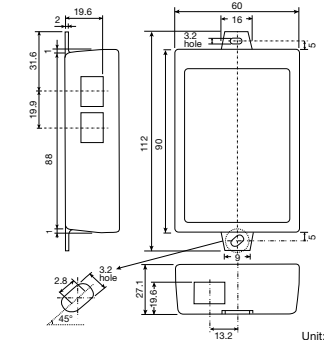

*1: USB communication conversion unit cable. Type-form (drive side): CAB0011 (1m), CAB0013 (3m), CAB0015 (5m)

*2: Cable is USB cable (USB1.1/2.0 A-B connect type) for PC side.

Unit: mm

Control power supply unit (Model: CPS002Z)

External dimensions

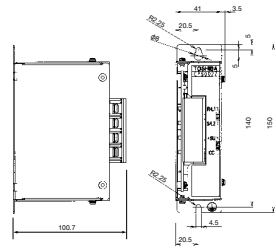

Connection diagram

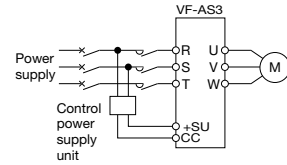

Type-form: CPS002Z
* CPS002Z can be used for both 240V and 480V class.

Operation panel (Model: CBVR-7B1)

External dimensions

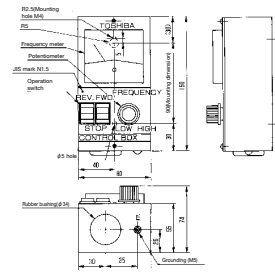

Panel cutout dimension

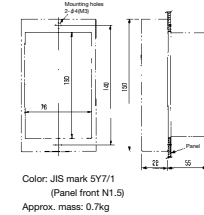

Color: JIS mark 5Y7/1
(Panel front N1.5)
Approx. mass: 0.7kg

Connection diagram

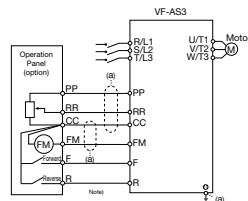

Note) The wire length should be 30m or less the drive and the operation panel.

Frequency meter <QS-60T (80Hz-1mAdc)>

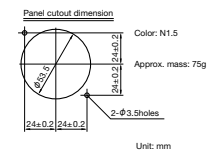
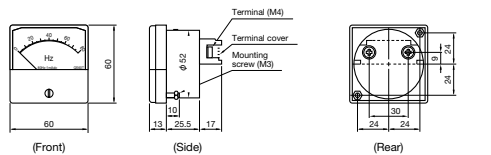

Color: N1.5
Approx. mass: 75g

Unit: mm

FRH-KIT

Potentiometer <RV30YN-20S-B302>

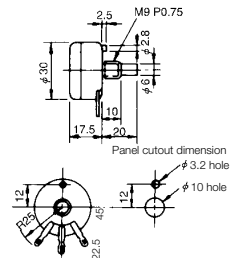

Potentiometer panel

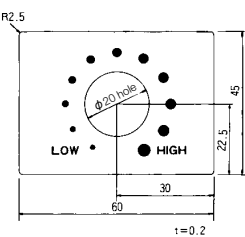

Potentiometer knob <K-3>

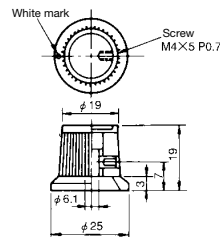

Totally enclosed box type for IP55

IP55 protection for direct mounting on wall.

Voltage class	Applied motor capacity(kW) : Dual rating															
	HD	0.4	0.75	1.5	2.2	4.0	5.5	7.5	11	15	18.5	22	30	37	45	55
ND	0.75	1.5	2.2	4.0	5.5	7.5	11	15	18.5	22	30	37	45	55	75	90



Standard specification

Item	480 V class																		
	A1E				A2E				A3E				A4E				A5E		
Applicable motor (kW)	HD	0.4	0.75	1.5	2.2	4.0	5.5	7.5	11	15	18.5	22	30	37	45	55	75		
	ND	0.75	1.5	2.2	4.0	5.5	7.5	11	15	18.5	22	30	37	45	55	75	90		
Rating	Type	VFAS3-																	
	Form	4004PCE 4007PCE 4015PCE 4022PCE 4037PCE 4055PCE 4075PCE 4110PCE 4150PCE 4185PCE 4220PCE 4300PCE 4370PCE 4450PCE 4550PCE 4750PCE																	
	Output capacity (kVA) ¹⁾	HD	1.1	1.7	3.0	4.3	7.1	9.7	12.6	17.9	24.2	29.9	35.3	46.9	56.8	67.1	80.8	111	
	Output current (A) ²⁾	HD	1.5	2.2	4.0	5.6	9.3	12.7	16.5	23.5	31.7	39.2	46.3	61.5	74.5	88.0	106	145	
Output voltage	3-phase 380V to 480V (The maximum output voltage is equal to the input supply voltage)																		
Overload current rating	HD	150%-1 minute, 180%-2 s																	
	ND	120%-1 minute, 135%-2 s																	
Voltage/frequency	3-phase 380 to 480V, 50/60Hz																		
	Tolerance	Voltage: 323V to 528V ³⁾ ; Frequency: +/-5%																	
Power supply	Required power supply capacity (kVA) ⁴⁾	HD	0.7	1.4	2.6	3.7	6.6	8.5	11.4	16.6	22.3	27.3	32.7	44.3	53.9	65.6	79.5	108	
	ND	1.2	2.4	3.4	6.1	8.3	10.9	15.6	21.3	26.4	31.4	42.0	52.4	63.2	77.0	103	125		
Output frequency range	0.01 to 590Hz (Default setting 0.01 to 80.0Hz)																		
Electrical braking	Dynamic braking circuit	Built-in																	
	Dynamic braking resistor	External braking resistor (Optional)																	
Degree of protection (IEC60529)	IP55 ⁵⁾																		
Cooling method	Forced air-cooled																		
Color	RAL7016																		
EMC filter	Built-in																		
DC reactor	Built-in																		
Environments	Use environments	Indoor use. Place not exposed to direct sunlight and free of corrosive gas, explosive gas, flammable gas, oil mist, or dust.																	
	Altitude	4800m or less (Current reduction necessary when above 1000m) ⁴⁾																	
	Chemical class	3C3 (IEC/EN60721)																	
	Mechanical class	3S3 (IEC/EN60721)																	
	Ambient temperature	-15 to +50°C (Current reduction necessary when above 40°C) ⁵⁾																	
	Storage temperature	-25 to +70°C ⁶⁾																	
Relative humidity	5 to 95% (Free from condensation)																		
Vibration	5.9m/s ² or less (10 - 55Hz)																		

¹⁾ Capacity is calculated at 440V for 480V class.
²⁾ Indicates rated output current setting when the PWM carrier frequency (parameter F300) is 4 kHz.
³⁾ Lower limit voltage for 480V class is 342V when inverter is used continuously (load of 100%).
⁴⁾ Current derating by 1% for each 100m above 1000m. For example, 90% at 2000m.
⁵⁾ Required power supply capacity varies with the value of the power supply side impedance (including input reactor and cables).
⁶⁾ Temperature applicable for a short term, e.g. during transportation
⁷⁾ UL type12 (UL type) without the top cover

External dimensions

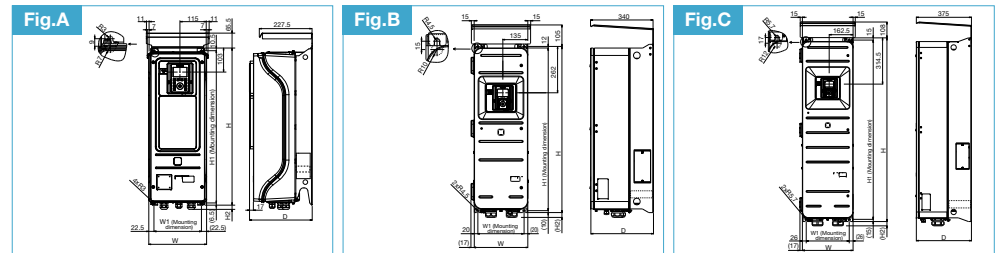

Input voltage class	Applicable motor (kW)		Drive type-form	Dimension (mm)			Frame Size	External dimension diagram	Approx.mass (kg)			
	HD	ND		W	H	D						
3-Phase 480V	0.4	0.75	VFAS3-4004PCE	250	678	271	205	661	19	A1E	A	13.2
	0.75	1.5	VFAS3-4007PCE	250	678	271	205	661	19	A1E	A	13.2
	1.5	2.2	VFAS3-4015PCE	250	678	271	205	661	19	A1E	A	13.4
	2.2	4.0	VFAS3-4022PCE	250	678	271	205	661	19	A1E	A	13.6
	4.0	5.5	VFAS3-4037PCE	250	678	271	205	661	19	A1E	A	13.7
	5.5	7.5	VFAS3-4055PCE	250	678	301	205	661	19	A2E	A	17.1
	7.5	11	VFAS3-4075PCE	250	678	301	205	661	19	A2E	A	17.4
	11	15	VFAS3-4110PCE	250	678	301	205	661	40	A3E	A	21.3
	15	18.5	VFAS3-4150PCE	250	678	301	205	661	40	A3E	A	21.8
	18.5	22	VFAS3-4185PCE	250	678	301	205	661	40	A3E	A	21.9
	22	30	VFAS3-4220PCE	290	910	340	250	888	26	A4E	B	51.5
	30	37	VFAS3-4300PCE	290	910	340	250	888	26	A4E	B	51.5
	37	45	VFAS3-4370PCE	290	910	340	250	888	26	A4E	B	52.5
	45	55	VFAS3-4450PCE	345	1250	375	293	1220	30	A5E	C	89
	55	75	VFAS3-4550PCE	345	1250	375	293	1220	30	A5E	C	91
	75	90	VFAS3-4750PCE	345	1250	375	293	1220	30	A5E	C	91