

SUPER LINE J SERIES THREE PHASE INDUCTION MOTOR



Feature and Benefits

Compact Size and Light Weight

Size and weight reductions have been achieved by the use of steel-plate frame and aluminium brackets in the small-capacity motors.

Highly Reliable Insulation Systems

Class B and F insulation systems are characterized by superior resistance to heat, humidity and chemicals for top-notch reliability.

Full Lineup

We have produced variety types of motors, ranged from 1/4 HP to 120 HP, thus providing a full lineup of motors ideal for any application.

Superlative Characteristics and High Reliability

Based on experience and technology accumulated over many years, along with an exacting quality-control system, each motor is ensured to exhibit only the finest characteristics.

Safety: All the rotating parts and the "live areas are made sure that it cannot be accidentally touched directly.

Smooth Acceleration: The low moment of inertia of the rotor combined with the motor's high acceleration torque, contributes to smooth starting and stopping.

Low Noise and Vibration Levels: This feature has been achieved due to our highly individualized electrical design, the ample rigidity and the precise machining of the motor frames and brackets, and the exact balancing of the rotor.

Significance of type designations and degrees of protection for three phase motor

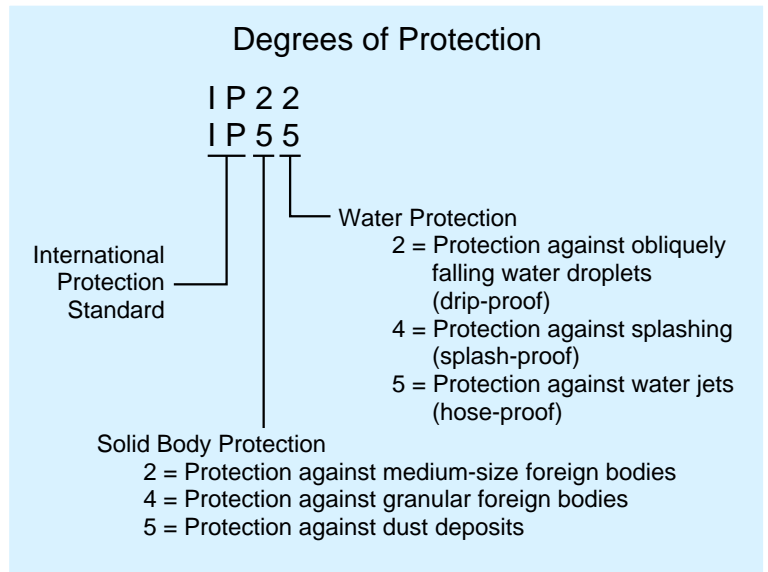
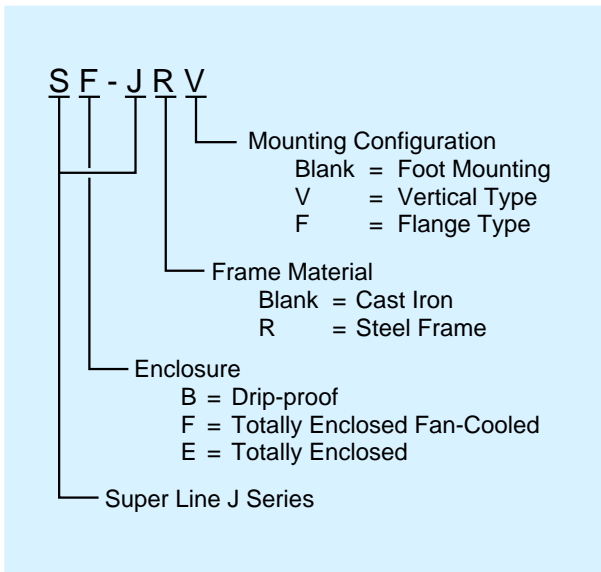

Motor Section

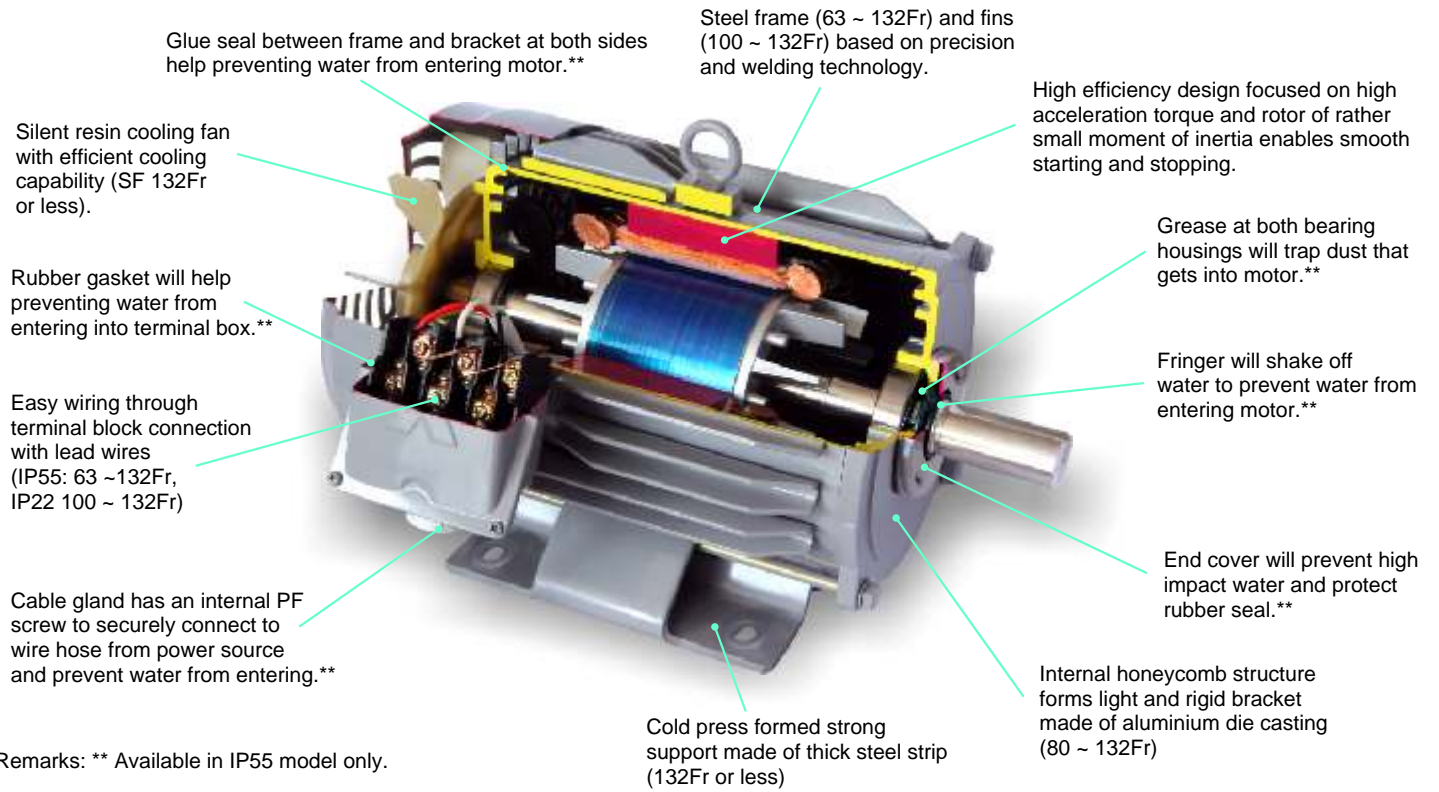

Connection

Construction of Lead Wires	Connection Diagram	
	LT	HT *
<p>Terminal Block</p> <p>Lead Wire</p>	<p>CONNECTION DIAGRAM</p> <p>HIGH VOLTAGE 380-440V Y-DIRECT STARTING</p> <p>LOW VOLTAGE 220V Δ-DIRECT STARTING</p> <p>LOW VOLTAGE 220V Y-Δ STARTING</p> <p>54N439-01</p>	<p>CONNECTION DIAGRAM</p> <p>380-440V DIRECT STARTING</p> <p>380-440V Y-Δ STARTING</p> <p>HT 54N440-01</p>
<p>IP 22: 80M ~ 90L IP 55: 160M ~ 250M</p> <p>Lead Wire</p>	<p>CONNECTION DIAGRAM (端子接続図)</p> <p>DUAL VOLTAGE (二種電圧)</p> <p>LOW VOLTAGE (低電圧) Δ 220V</p> <p>HIGH VOLTAGE (高電圧) Δ 380-440V</p> <p>SOURCE (電源)</p> <p>LT 54N437-01</p>	<p>CONNECTION DIAGRAM (端子接続図)</p> <p>Y-Δ STARTING (スターデルタ始動)</p> <p>STARTING (始動) Δ</p> <p>RUNNING (運転) Δ</p> <p>SOURCE (電源)</p> <p>HT 54N438-01</p>

* HT can be used only with motors 5HP and above.

Standard Specifications

Item	Specifications																													
Voltage and Frequency	LT: 10HP and below = 220/380~415V 50Hz, 220/440V 60Hz HT: 5HP and above = 380~415V 50Hz, 380~440V 60Hz(Suitable for Y-Δ starting)																													
Enclosure Construction and Degrees of Protection	<table border="1"> <thead> <tr> <th rowspan="2">Degrees of Protection</th> <th rowspan="2">Enclosure Construction</th> <th rowspan="2">Frame No.</th> <th colspan="3">Model Name</th> </tr> <tr> <th>Horizontal</th> <th>Vertical</th> <th>Flange*</th> </tr> </thead> <tbody> <tr> <td rowspan="3">IP55</td> <td rowspan="3">Totally Enclosed Fan-Cooled Type</td> <td>63M ~ 132M</td> <td>SF-JR</td> <td>SF-JRV</td> <td>SF-JRF</td> </tr> <tr> <td>160M ~ 180L</td> <td>SF-J</td> <td>SF-JV</td> <td>SF-JF</td> </tr> <tr> <td>180L ~ 250M</td> <td>SF-J</td> <td>-</td> <td>-</td> </tr> <tr> <td>IP22</td> <td>Drip-proof</td> <td>80M ~ 132M</td> <td>SB-JR</td> <td>SB-JRV</td> <td>-</td> </tr> </tbody> </table> <p>* Standard vertical-type motor can be used for indoor flange type.</p>	Degrees of Protection	Enclosure Construction	Frame No.	Model Name			Horizontal	Vertical	Flange*	IP55	Totally Enclosed Fan-Cooled Type	63M ~ 132M	SF-JR	SF-JRV	SF-JRF	160M ~ 180L	SF-J	SF-JV	SF-JF	180L ~ 250M	SF-J	-	-	IP22	Drip-proof	80M ~ 132M	SB-JR	SB-JRV	-
Degrees of Protection	Enclosure Construction				Frame No.	Model Name																								
		Horizontal	Vertical	Flange*																										
IP55	Totally Enclosed Fan-Cooled Type	63M ~ 132M	SF-JR	SF-JRV	SF-JRF																									
		160M ~ 180L	SF-J	SF-JV	SF-JF																									
		180L ~ 250M	SF-J	-	-																									
IP22	Drip-proof	80M ~ 132M	SB-JR	SB-JRV	-																									
Frame Material	63M ~ 132M Steel Plate 160M ~ 250M Cast Iron																													
Power Transmission System	Direct-coupled, Special purpose system for 2-pole machines with an output of 15HP or above. Direct-coupled and belt-driven, dual-purpose system for machines with 4 or more poles.																													
Direction of Rotation	Counter-Clockwise (CCW) viewed from shaft-end side.																													
Thermal Class	IP22 : 90L and below Class B 100L and above Class F IP55 : All models Class F																													
Circumstance Condition	Ambient Temperature	-20 ~ +40°C																												
	Ambient Humidity	85% RH or less (for Drip-proof Structure) 95% RH or less (for Totally Enclosed Structure)																												
	Altitude	Less than 1,000m above sea level																												
	Environment	No bursting / erosive gas or vapor																												
Connection Type	<table border="1"> <thead> <tr> <th>Degrees of Protection</th> <th>Frame No.</th> <th>No.of leads</th> <th>Connection Type</th> </tr> </thead> <tbody> <tr> <td rowspan="2">IP55</td> <td>63M ~ 132M</td> <td>6</td> <td>Terminal Block</td> </tr> <tr> <td>160M ~ 250M</td> <td>6</td> <td>Lead Wire (also suitable for Y-Δ starting)</td> </tr> <tr> <td rowspan="2">IP22</td> <td>80M ~ 90L</td> <td>6</td> <td>Lead Wire</td> </tr> <tr> <td>100L ~ 132M</td> <td>6</td> <td>Terminal Block</td> </tr> </tbody> </table>	Degrees of Protection	Frame No.	No.of leads	Connection Type	IP55	63M ~ 132M	6	Terminal Block	160M ~ 250M	6	Lead Wire (also suitable for Y-Δ starting)	IP22	80M ~ 90L	6	Lead Wire	100L ~ 132M	6	Terminal Block											
Degrees of Protection	Frame No.	No.of leads	Connection Type																											
IP55	63M ~ 132M	6	Terminal Block																											
	160M ~ 250M	6	Lead Wire (also suitable for Y-Δ starting)																											
IP22	80M ~ 90L	6	Lead Wire																											
	100L ~ 132M	6	Terminal Block																											
Coating Colour	Munsell N5.5 (Gray)																													
Conformed Standard	IEC 60034-1 & JIS C 4210 (for Horizontal Type), JEC-2137-2000 (for Vertical Type)																													

SB-JR 80M~132M HORIZONTAL TYPE

Drip-Proof Type, IP 22 Degrees of Protection



SB-JR 1HP 4P 80M

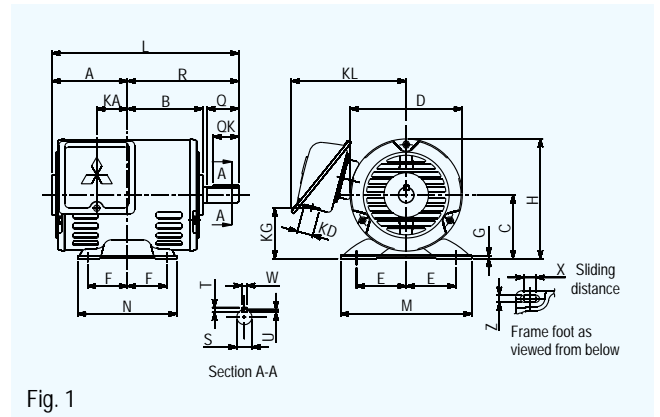

Fig. 1

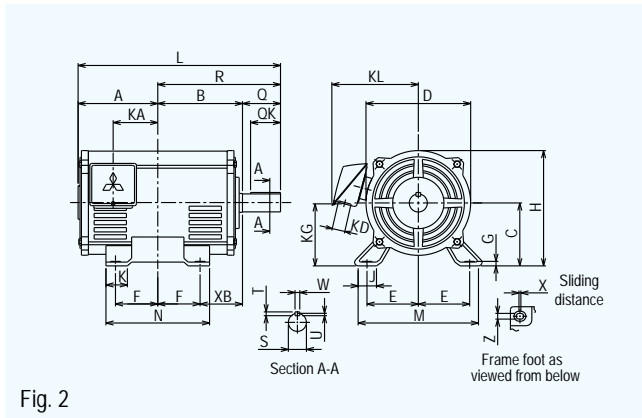

Fig. 2

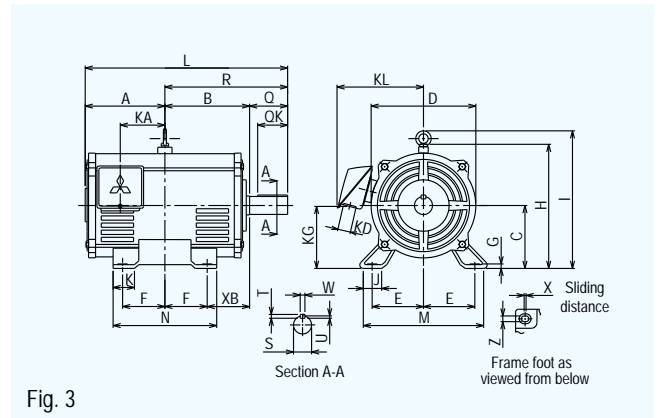

Fig. 3

Dimensions (mm)

Model	Frame No.	Output HP (kW)			Fig.	Motor																	Terminal Box				
		2-Pole	4-Pole	6-Pole		A	B	C*	D	E	F	G	H	I	J	K	L	M	ML	N	X	XB	Z	KA	KG	KD	KL
SB-JR	80M	1(0.75)	1(0.75)	1/2(0.4)	1	95	95	80	141	62.5	50	3.2	150.5	-	-	-	235	160	-	125	15	50	9	39.5	63	27	144
	90L	2(1.5), 3(2.2)	2(1.5)	1(0.75)		112.5	112.5	90	168	70	62.5	4	174	-	-	-	281	175	-	150	15	56	9	53	76	27	157
	100L	-	3(2.2)	2(1.5)	2	130	128	100	168	80	70	6.5	184	-	40	45	323	200	212	180	4	63	12	65	86	27	157
	112M	5(3.7)	5(3.7)	3(2.2)		136	135	112	190	95	70	6.5	220	254	40	45	336	230	242	180	4	70	12	69	101	27	168
	132S	7.5(5.5), 10(7.5)	7.5(5.5)	5(3.7)	3	153	152	132	220	108	70	6.5	255	289	40	45	392	256	268	180	4	89	12	75	118	27	185
	132M	-	10(7.5)	7.5(5.5)		172	171	132	220	108	89	6.5	255	289	40	45	430	256	268	218	4	89	12	94	118	27	185

* The perpendicular variation of tolerance for the shaft center is ± 0.5

Model	Frame No.	Shaft End						Bearing No.		Approximate Weight (kg)			Approximate Packing Dimensions (LxWxH)	Packing Weight (kg)			
		Q	QK	R	S	T	U	W	Drive End	Opposite	2-Pole	4-Pole		6-Pole	2-Pole	4-Pole	6-Pole
SB-JR	80M	40	32	140	19 j6	6	3.5	6	6204ZZ	6203ZZ	9	11	11	295 x 270 x 206	10	10.8	12
	90L	50	40	168.5	24 j6	7	4	8	6205ZZ	6204ZZ	16, 16	16	16	350 x 280 x 350	17, 16	17	17
	100L	60	45	193	28 j6	7	4	8	6206ZZ	6205ZZ	-	22	24	409 x 355 x 300	-	21.2	27
	112M	60	45	200	28 j6	7	4	8	6207ZZ	6206ZZ	27	30	31	477 x 399 x 315	31	34	35
	132S	80	63	239	38 k6	8	5	10	6308ZZ	6207ZZ	38, 42	40	41	526 x 403 x 347	42, 46	44	45
	132M	80	63	258	38 k6	8	5	10	6308ZZ	6207ZZ	-	51	52	526 x 403 x 347	-	55	56

SB-JRV 80M~132M VERTICAL TYPE

Drip-Proof Type, IP 22 Degrees of Protection



SB-JRV 10HP 4P 132M

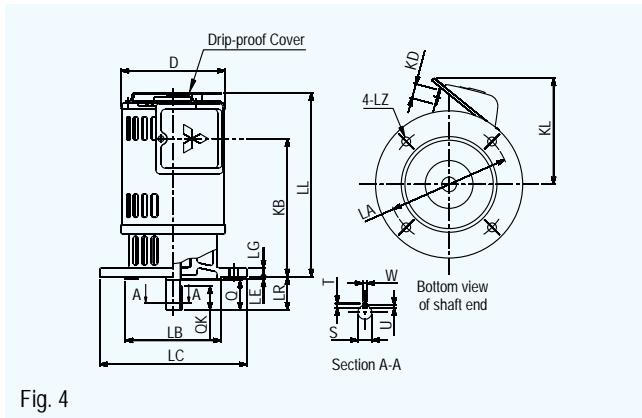

Fig. 4

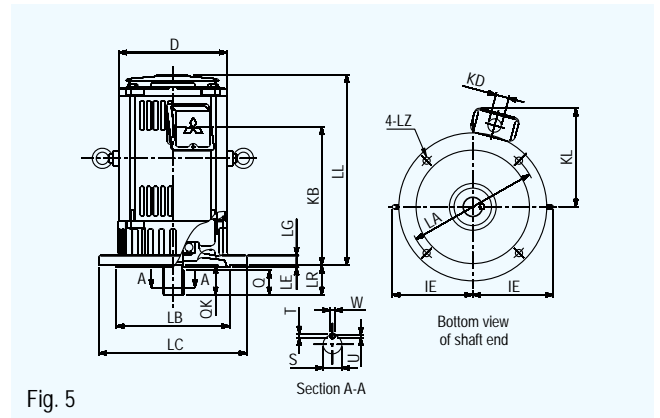

Fig. 5

Dimensions (mm)

Model	Flange No.	Frame No.	Output HP (kW)			Fig.	Motor										Terminal Box		
			2-Pole	4-Pole	6-Pole		D	IE	LA	LB	LC	LE	LG	LL*	LZ	KB	KD	KL	
SB-JRV	FF165	80M	1(0.75)	1(0.75)	1/2(0.4)	4	141	-	165	130 j6	200	3.5	12	234(227)	12	171.5	27	145	
	FF165	90L	2(1.5), 3(2.2)	2(1.5)	1(0.75)		168	-	165	130 j6	200	3.5	12	270(261)	12	201.5	27	158	
	FF215	100L	-	3(2.2)	2(1.5)	5	168	-	215	180 j6	250	4	16	320(300)	14.5	237	27	155	
	FF215	112M	5(3.7)	5(3.7)	3(2.2)		190	141.5	215	180 j6	250	4	16	352(329)	14.5	263	27	166	
	FF265	132S	7.5(5.5), 10(7.5)	7.5(5.5)	5(3.7)		220	156.5	265	230 j6	300	4	20	393(369)	14.5	292	27	181	
	FF265	132M	-	10(7.5)	7.5(5.5)		220	156.5	265	230 j6	300	4	20	431(407)	14.5	330	27	181	

* () is dimension of vertical type without drip-proof cover.

Model	Flange No.	Frame No.	Shaft End						Bearing No.		Approximate Weight (kg)			Approximate Packing Dimensions (LxWxH)	Packing Weight (kg)			
			LR	Q	QK	S	T	U	W	Drive End	Opposite	2-Pole	4-Pole		6-Pole	2-Pole	4-Pole	6-Pole
SB-JRV	FF165	80M	40	40	32	19 j6	6	3.5	6	6204ZZ	6203ZZ	12	14	14	305 x 260 x 235	14	16	16
	FF165	90L	50	50	40	24 j6	7	4	8	6205ZZ	6204ZZ	19, 19	19	19	370 x 280 x 235	21, 21	21	21
	FF215	100L	60	60	45	28 j6	7	4	8	6206ZZ	6205ZZ	-	28	30	430 x 340 x 330	-	30	32
	FF215	112M	60	60	45	28 j6	7	4	8	6207ZZ	6206ZZ	37	40	41	390 x 387 x 354	41	44	45
	FF265	132S	80	80	63	38 k6	8	5	10	6308ZZ	6207ZZ	52, 56	54	55	569 x 427 x 384	59, 63	61	62
	FF265	132M	80	80	63	38 k6	8	5	10	6308ZZ	6207ZZ	-	67	68	607 x 427 x 384	-	74	75

SF-JR 63M~132M HORIZONTAL TYPE

Totally Enclosed Fan Cooled Type, IP 55 Degrees of Protection



SF-JR 3HP 4P 100L

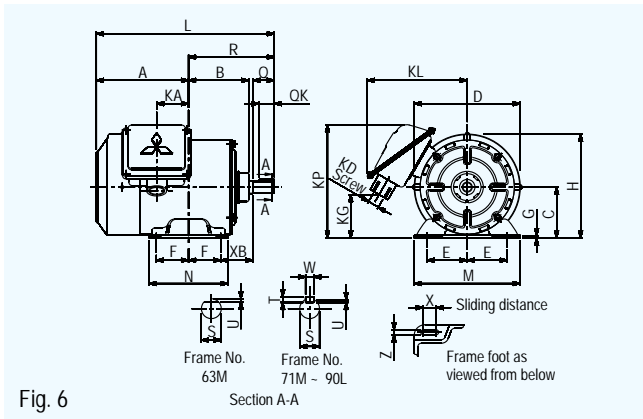

Fig. 6

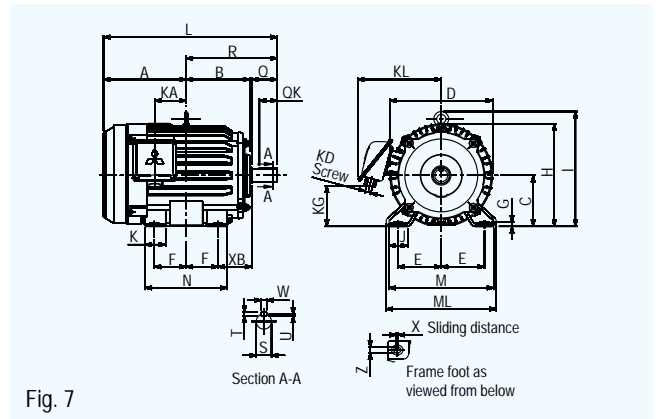

Fig. 7

Dimensions (mm)

Model	Frame No.	Output HP (kW)			Fig.	Motor																	Terminal Box					
		2-Pole	4-Pole	6-Pole		A	B	C*	D	E	F	G	H	I	J	K	L	M	ML	N	X	XB	Z	KA	KG	KD	KL	KP**
SF-JR	63M	1/4(0.2)	1/4(0.2)	-	6	121.4	73.6	63	130	50	40	2.3	126.3	-	-	-	224.4	135	-	100	12	40	7	38.4	75	PF1/2	130	162
	71M	1/2(0.4)	1/2(0.4)	1/4(0.2)		128.5	83	71	147.6	56	45	3.2	144.8	-	-	-	248.5	148	-	110	18	45	7	44.5	67	PF1/2	140	161
	80M	1(0.75)	1(0.75)	1/2(0.4)		122	98	80	161.6	62.5	50	3.2	165.4	-	-	-	262	160	-	125	15	50	9	39.5	38	PF3/4	145	-
	90L	2(1.5), 3(2.2)	2(1.5)	1(0.75)		143	117	90	183.6	70	62.5	4	186.3	-	-	-	311.5	175	-	150	15	56	9	53	59	PF3/4	158	-
	100L	-	3(2.2)	2(1.5)	7	173	131	100	207	80	70	6.5	203.5	230	40	45	366	200	212	180	4	63	12	65	64	PF3/4	170	-
	112M	5(3.7)	5(3.7)	3(2.2)		181	138	112	228	95	70	6.5	226	253	40	45	381	230	242	180	4	70	12	69	87	PF3/4	182	-
	132S	7.5(5.5), 10(7.5)	7.5(5.5)	5(3.7)		211.5	155	132	266	108	70	6.5	265	288	40	45	450.5	256	268	180	4	89	12	75	96	PF1	210	-
	132M	-	10(7.5)	7.5(5.5)		230.5	174	132	266	108	89	6.5	265	288	40	45	488.5	256	268	218	4	89	12	94	96	PF1	210	-

* The perpendicular variation of tolerance for the shaft center is $\frac{0}{-0.5}$
 ** This dimension is for model which $KP > H$ only.

Model	Frame No.	Shaft End						Bearing No.		Approximate Weight (kg)			Approximate Packing Dimensions (LxWxH)	Packing Weight (kg)			
		Q	QK	R	S	T	U	W	Drive End	Opposite	2-Pole	4-Pole		6-Pole	2-Pole	4-Pole	6-Pole
SF-JR	63M	23	-	103	11 h6	-	1	-	6201ZZ	6201ZZ	6.5	6.6	-	245 x 221 x 193	5.7	6	-
	71M	30	25	120	14 j6	5	3	5	6202ZZ	6201ZZ	8.0	9.2	9.0	275 x 256 x 180	7.2	8	8
	80M	40	32	140	19 j6	6	3.5	6	6204ZZ	6203ZZ	10.5	11	11	315 x 270 x 206	10.7	11.7	11.5
	90L	50	40	168.5	24 j6	7	4	8	6205ZZ	6204ZZ	17, 20.5	20	21.5	368 x 280 x 226	17.2, 21	20	19.5
	100L	60	45	193	28 j6	7	4	8	6206ZZ	6205ZZ	-	24	25	430 x 355 x 300	-	28	27
	112M	60	45	200	28 j6	7	4	8	6207ZZ	6206ZZ	33	36	37	477 x 399 x 315	40	42	44
	132S	80	63	239	38 k6	8	5	10	6308ZZ	6207ZZ	47, 55	48	50	579 x 435 x 347	55, 63	56	58
	132M	80	63	258	38 k6	8	5	10	6308ZZ	6207ZZ	-	58	61	579 x 435 x 347	-	66	69

SF-J 160M~250M HORIZONTAL TYPE

Totally Enclosed Fan Cooled Type, IP 55 Degrees of Protection



SF-J 75HP 4P 225S

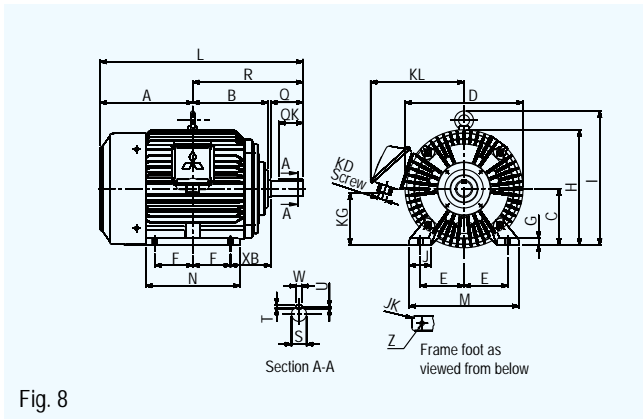

Fig. 8

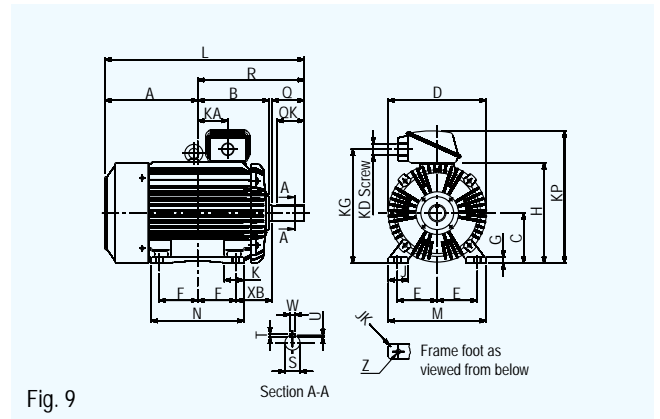

Fig. 9

Dimensions (mm)

Model	Frame No.	Output HP (kW)			Fig.	Motor															Terminal Box						
		2-Pole	4-Pole	6-Pole		A	B	C*	D	E	F	G	H	I	J	JK	K	L	M	N	XB	Z	KA	KG	KD	KL	KP
SF-J	160M	15(11), 20(15)	15(11)	10(7.5)	8	252	207	160	324	127	105	20	322	373	55	R6	-	575	310	260	108	15	-	127	PF1 1/4	271	-
	160L	25(18.5)	20(15)	15(11)		274	229	160	324	127	127	20	322	373	55	R6	-	619	310	304	108	15	-	127	PF1 1/4	271	-
	180M	30(22)	25(18.5), 30(22)	20(15)		294.5	239	180	376	139.5	120.5	22	367	427	70	R6	-	646	350	300	121	15	-	151	PF1 1/2	295	-
	180L	40(30)	40(30)	25(18.5), 30(22)	313.5	258	180	376	139.5	139.5	22	367	427	70	R6	-	684	350	338	121	15	-	151	PF1 1/2	295	-	
	200L	50(37), 60(45)	50(37), 60(45)	40(30), 50(37)	370.5	281	200	410	159	152.5	25	405	-	80	R6	78	(766) 796	390	369	133	18.5	120	476	PF2	-	550	
	225S	75(55)	75(55)	60(45)	380	287.5	225	459	178	143	28	457	-	80	R8	82	(782) 812	430	350	149	18.5	120	528	PF2	-	602	
	250S	-	100(75)	-	417.5	318.7	250	495	203	155.5	30	-	-	80	R8	95	881	486	387	168	24	136.5	560	PF2 1/2	-	643	
250M	-	120(90)	-	436.5	337.7	250	495	203	174.5	30	-	-	80	R8	95	919	486	425	168	24	155.5	560	PF2 1/2	-	643		

* The perpendicular variation of tolerance for the shaft center is $\begin{matrix} 0 \\ -0.5 \end{matrix}$

Model	Frame No.	Shaft End						Bearing No.		Approximate Weight (kg)			Approximate Packing Dimensions (LxWxH)	Packing Weight (kg)			
		Q	QK	R	S	T	U	W	Drive End	Opposite	2-Pole	4-Pole		6-Pole	2-Pole	4-Pole	6-Pole
SF-J	160M	110	90	323	42 k6	8	5	12	6309ZZ	6308ZZ	105, 115	107	107	743 x 601 x 494	126, 136	128	128
	160L	110	90	345	42 k6	8	5	12	6309ZZ	6308ZZ	145	135	135	787 x 601 x 494	166	156	156
	180M	110	90	351.5	48 k6	9	5.5	14	6311ZZ	6310ZZ	190	185, 195	195	814 x 651 x 548	214	209, 219	219
	180L	110	90	370.5	55 m6	10	6	16	6312ZZ	6310ZZ	220	230	220, 235	852 x 651 x 548	244	254	244, 259
	200L	(110) 140	(90) 110	(395.5) 425.5	(55 m6) 60 m6	(10) 11	(6) 7	(16) 18	(6312ZZC3) 6313ZZ	(6311ZZC3) 6311ZZ	280, 195	285, 310	295, 340	964 x 542 x 691	307, 222	312, 337	322, 367
	225S	(110) 140	(90) 110	(402) 432	(55 m6) 60 m6	(10) 11	(6) 7	(16) 18	(6312ZZC3) 6315ZZ	(6312ZZC3) 6312ZZ	315	345	370	980 x 591 x 774	345	375	400
	250S	140	110	463.5	75 m6	12	7.5	20	6318ZZ	6315ZZ	-	485	-	1087 x 627 x 824	-	500	-
250M	140	110	482.5	75 m6	12	7.5	20	6318ZZ	6315ZZ	-	516	-	1087 x 627 x 824	-	531	-	

() is dimension for 2-pole motors.

SF-JRV 63M~132M & SF-JV 160M~180L VERTICAL TYPE

Totally Enclosed Fan Cooled Type, IP 55 Degrees of Protection



SF-JRV 10HP 4P 132M

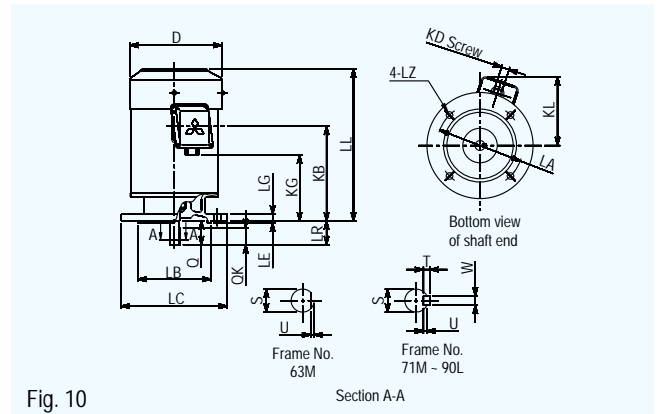

Fig. 10

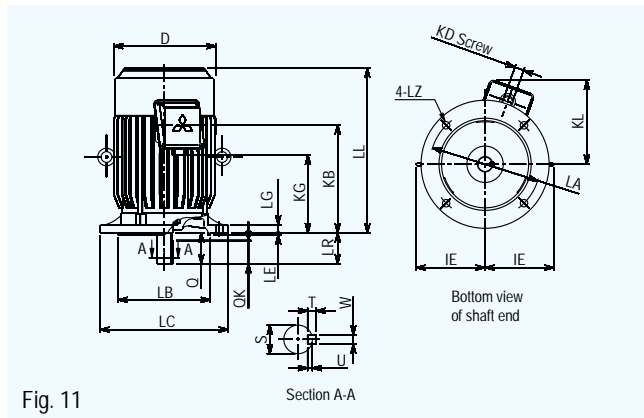

Fig. 11

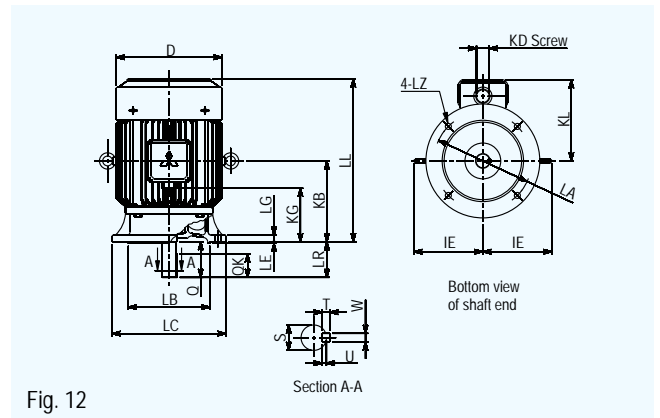

Fig. 12

Dimensions (mm)

Model	Flange No.	Frame No.	Output HP (kW)			Fig.	Motor								Terminal Box			
			2-Pole	4-Pole	6-Pole		D	IE	LA	LB	LC	LE	LG	LL	LZ	KD	KG	KL
SF-JRV	FF130	63M	1/4(0.2)	1/4(0.2)	-	10	127	-	130	110 j6	160	3.5	10	208	10	PF1/2	58	125
	FF130	71M	1/2(0.4)	1/2(0.4)	1/4(0.2)		148	-	130	110 j6	160	3.5	10	229	10	PF1/2	80	138
	FF165	80M	1(0.75)	1(0.75)	1/2(0.4)		166	-	165	130 j6	200	3.5	12	226	12	PF3/4	78	144
	FF165	90L	2(1.5), 3(2.2)	2(1.5)	1(0.75)		186.3	-	165	130 j6	200	3.5	12	288.5	12	PF3/4	133	156
	FF215	100L	-	3(2.2)	2(1.5)	11	207	130	215	180 j6	250	4	16	321	14.5	PF3/4	148	169
	FF215	112M	5(3.7)	5(3.7)	3(2.2)		230	141	215	180 j6	250	4	16	351	14.5	PF3/4	174	180
	FF265	132S	7.5(5.5), 10(7.5)	7.5(5.5)	5(3.7)		266	156	265	230 j6	300	4	20	392.5	14.5	PF1	173	213
	FF265	132M	-	10(7.5)	7.5(5.5)		266	156	265	230 j6	300	4	20	430.5	14.5	PF1	211	213
SF-JV	FF300	160M	15(11), 20(15)	15(11)	10(7.5)	12	324	213	300	250 j6	350	5	20	500	18.5	PF1 1/4	147	259
	FF300	160L	25(18.5)	20(15)	15(11)		324	213	300	250 j6	350	5	20	544	18.5	PF1 1/4	169	259
	FF350	180M	30(22)	25(18.5), 30(22)	20(15)		376	247	350	300 j6	400	5	20	576	18.5	PF1 1/2	176	284
	FF350	180L	40(30)	40(30)	25(18.5), 30(22)		376	247	350	300 j6	400	5	20	614	18.5	PF1 1/2	195	284

Model	Flange No.	Frame No.	Shaft End				Bearing No.		Approximate Weight (kg)			Approximate Packing Dimensions (LxWxH)	Packing Weight (kg)					
			LR	Q	QK	S	T	U	W	Drive End	Opposite		2-Pole	4-Pole	6-Pole	2-Pole	4-Pole	6-Pole
SF-JRV	FF130	63M	23	23	-	11 h6	-	1	-	6201ZZ	6201ZZ	6.5	6.6	-	318 x 256 x 180	6.8	6.9	-
	FF130	71M	30	30	25	14 j6	5	3	5	6202ZZ	6201ZZ	8.0	9.2	9.0	318 x 256 x 180	9.3	9.8	9.4
	FF165	80M	40	40	32	19 j6	6	3.5	6	6204ZZ	6203ZZ	12	13	13	368 x 280 x 226	13	14.5	13.5
	FF165	90L	50	50	40	24 j6	7	4	8	6205ZZ	6204ZZ	19.5, 23	22.5	21.5	425 x 280 x 226	19.6, 23.8	23	22.5
	FF215	100L	60	60	45	28 j6	7	4	8	6206ZZ	6205ZZ	-	28	29	456 x 355 x 300	-	29.5	31.5
	FF215	112M	60	60	45	28 j6	7	4	8	6207ZZ	6206ZZ	37	40	42	507 x 401 x 357	44	47	49
	FF265	132S	80	80	63	38 k6	8	5	10	6308ZZ	6207ZZ	55, 63	56	58	569 x 459 x 386	63, 71	64	66
	FF265	132M	80	80	63	38 k6	8	5	10	6308ZZ	6207ZZ	-	66	68	637 x 459 x 386	-	74	76
SF-JV	FF300	160M	110	110	90	42 k6	8	5	12	6309ZZ	6308ZZ	110, 120	110	110	778 x 602 x 557	134, 144	134	134
	FF300	160L	110	110	90	42 k6	8	5	12	6309ZZ	6308ZZ	150	140	140	822 x 602 x 557	174	164	164
	FF350	180M	110	110	90	48 k6	9	5.5	14	6311ZZ	6310ZZ	195	190, 200	200	854 x 652 x 610	222	217, 227	227
	FF350	180L	110	110	90	55 m6	10	6	16	6312ZZ	6310ZZ	225	235	225, 240	892 x 652 x 610	252	262	252, 267

Three Phase Motor Characteristics

SF-JR(V) IP55 63M~132M (Thermal Class F), SF-J(V) 160M~250M (Thermal Class F)

LT (220/ 380~415V 50Hz, 220/ 440V 60Hz)

Pole	Output		Frame No.	Full Load Current(A) / Full Load Revolution(r/min)				
	HP	kW		220V 50Hz	380V 50Hz	415V 50Hz	220V 60Hz	440V 60Hz
2	1/4	0.2	63	0.97 / 2810	0.56 / 2810	0.58 / 2840	0.94 / 3360	0.53 / 3380
	1/2	0.4	71	1.73 / 2830	1.0 / 2830	1.0 / 2860	1.65 / 3420	0.9 / 3440
	1	0.75	80	3.1 / 2830	1.8 / 2830	1.8 / 2860	2.9 / 3400	1.6 / 3430
	2	1.5	90L	5.6 / 2860	3.2 / 2860	3.1 / 2870	5.2 / 3440	2.8 / 3450
	3	2.2	90L	7.8 / 2850	4.5 / 2850	4.3 / 2870	7.6 / 3430	4.0 / 3460
	5	3.7	112M	12.8 / 2890	7.4 / 2890	7.2 / 2910	12.6 / 3470	6.5 / 3490
	7.5	5.5	132S	20.1 / 2900	11.6 / 2900	11.6 / 2910	18.9 / 3480	10 / 3500
	10	7.5	132S	25 / 2910	14.5 / 2910	14.1 / 2920	24.5 / 3490	12.4 / 3510
4	1/4	0.2	63	1.11 / 1430	0.64 / 1430	0.69 / 1440	0.97 / 1730	0.61 / 1750
	1/2	0.4	71	2.0 / 1410	1.15 / 1410	1.2 / 1430	1.8 / 1700	1.0 / 1730
	1	0.75	80	3.3 / 1400	1.9 / 1400	1.95 / 1410	3.0 / 1700	1.7 / 1720
	2	1.5	90L	5.9 / 1430	3.4 / 1430	3.4 / 1440	5.5 / 1710	3.1 / 1730
	3	2.2	100L	8.7 / 1420	5.0 / 1420	4.9 / 1430	8.5 / 1710	4.6 / 1730
	5	3.7	112M	13.7 / 1420	7.9 / 1420	7.7 / 1430	13.5 / 1710	7.2 / 1730
	7.5	5.5	132S	20.4 / 1430	11.8 / 1430	11.1 / 1440	19.9 / 1720	10.3 / 1740
	10	7.5	132M	27 / 1430	15.4 / 1430	14.6 / 1440	26 / 1720	13.5 / 1740
6	1/4	0.2	71	1.21 / 920	0.7 / 920	0.7 / 930	1.12 / 1100	0.65 / 1120
	1/2	0.4	80	2.25 / 920	1.3 / 920	1.3 / 930	2.1 / 1100	1.2 / 1110
	1	0.75	90L	3.6 / 940	2.1 / 940	2.2 / 950	3.5 / 1130	2.0 / 1150
	2	1.5	100L	7.0 / 930	4.0 / 930	4.0 / 940	6.6 / 1110	3.6 / 1120
	3	2.2	112M	9.5 / 940	5.5 / 940	5.4 / 950	9.0 / 1120	5.1 / 1140
	5	3.7	132S	15.2 / 940	8.8 / 940	8.4 / 950	14.2 / 1130	7.8 / 1150
	7.5	5.5	132M	22 / 950	12.8 / 950	13 / 960	21 / 1140	11.5 / 1150

HT (380~415V 50Hz, 380~440V 60Hz)

Pole	Output		Frame No.	Full Load Current(A) / Full Load Revolution(r/min)			
	HP	kW		380V 50Hz	415V 50Hz	380V 60Hz	440V 60Hz
2	5	3.7	112M	7.5 / 2890	7.3 / 2910	7.3 / 3470	6.6 / 3490
	7.5	5.5	132S	11.6 / 2900	11.6 / 2910	10.9 / 3480	10 / 3500
	10	7.5	132S	14.4 / 2900	14.0 / 2920	14.2 / 3480	12.4 / 3510
	15	11	160M	21.5 / 2910	20.5 / 2920	21 / 3490	18.5 / 3510
	20	15	160M	28 / 2910	27 / 2920	27 / 3490	24 / 3510
	25	18.5	160L	34 / 2910	33 / 2930	33 / 3490	29 / 3510
	30	22	180M	42 / 2910	39 / 2930	41 / 3490	36 / 3510
	40	30	180L	55 / 2920	52 / 2940	54 / 3490	47 / 3520
	50	37	200L	69 / 2920	67 / 2940	67 / 3510	60 / 3530
	60	45	200L	83 / 2920	80.5 / 2940	81 / 3510	72 / 3530
	75	55	225S	103 / 2930	101 / 2940	101 / 3520	89 / 3540
	5	3.7	112M	7.9 / 1420	7.7 / 1430	7.8 / 1710	7.2 / 1730
	7.5	5.5	132S	11.8 / 1430	11.1 / 1440	11.5 / 1720	10.3 / 1740
	10	7.5	132M	15.5 / 1430	14.5 / 1440	15.0 / 1720	13.4 / 1740
	15	11	160M	22.5 / 1430	21.5 / 1440	21.5 / 1720	19 / 1740
	4	20	15	160L	30 / 1450	31 / 1460	28.5 / 1740
25		18.5	180M	36 / 1460	35 / 1470	35 / 1750	32 / 1760
30		22	180M	43 / 1460	42 / 1470	42 / 1750	38 / 1760
40		30	180L	58 / 1460	56 / 1470	56 / 1750	49 / 1760
50		37	200L	69 / 1450	65 / 1460	69 / 1750	60 / 1770
60		45	200L	83.5 / 1450	82 / 1460	82 / 1750	72 / 1770
75		55	225S	104 / 1460	102 / 1470	101 / 1760	90 / 1770
100		75	250S	138 / 1450	129 / 1460	137 / 1730	118 / 1750
120		90	250M	179 / 1480	174 / 1480	175 / 1722	155 / 1745
5		3.7	132S	8.9 / 940	8.5 / 950	8.3 / 1130	7.9 / 1150
7.5		5.5	132M	12.8 / 950	13 / 960	12.1 / 1140	11.5 / 1150
10		7.5	160M	16.5 / 950	16.5 / 960	16 / 1130	14.5 / 1150
15		11	160L	24 / 960	24 / 970	23 / 1140	21 / 1160
20		15	180M	32 / 960	32 / 970	31 / 1150	28 / 1170
25		18.5	180L	39 / 960	37 / 970	38 / 1150	33 / 1170
30		22	180L	45 / 960	43 / 970	44 / 1150	39 / 1170
40	30	200L	60 / 960	59 / 970	58 / 1150	51 / 1170	
50	37	200L	74 / 960	74 / 970	72 / 1150	64 / 1170	
60	45	225S	89 / 960	90 / 975	86 / 1160	76 / 1170	

SB-JR(V) IP22 80M~90L(Thermal Class B), 100L~132M (Thermal Class F)

LT (220/ 380~415V 50Hz, 220/ 440V 60Hz)

Pole	Output		Frame No.	Full Load Current(A) / Full Load Revolution(r/min)				
	HP	kW		220V 50Hz	380V 50Hz	415V 50Hz	220V 60Hz	440V 60Hz
4	1	0.75	80M	3.5 / 1400	2.0 / 1400	2.3 / 1410	2.9 / 1700	1.7 / 1720
	2	1.5	90L	6.2 / 1450	3.6 / 1450	4.0 / 1460	5.5 / 1720	3.2 / 1740
	3	2.2	100L	8.7 / 1420	5.0 / 1420	4.9 / 1430	8.5 / 1710	4.6 / 1730
	5	3.7	112M	13.7 / 1420	7.9 / 1420	7.7 / 1430	13.5 / 1710	7.2 / 1730
	7.5	5.5	132S	20.4 / 1430	11.8 / 1430	11.8 / 1440	19.4 / 1720	11.2 / 1730
	10	7.5	132M	26.4 / 1440	15.2 / 1440	15.2 / 1450	25.4 / 1730	13.7 / 1740

HT (380~415V 50Hz, 380~440V 60Hz)

Pole	Output		Frame No.	Full Load Current(A) / Full Load Revolution(r/min)			
	HP	kW		380V 50Hz	415V 50Hz	380V 60Hz	440V 60Hz
4	5	3.7	112M	7.9 / 1420	7.7 / 1430	7.8 / 1710	7.2 / 1730
	7.5	5.5	132S	11.8 / 1430	11.8 / 1440	11.2 / 1720	10.6 / 1730
	10	7.5	132M	15.4 / 1440	15.2 / 1450	14.7 / 1730	13.6 / 1750

Three Phase Motor Characteristics

LT (220/ 380~415V 50Hz, 220/ 440V 60Hz)

SF-JR(V) IP55 63M~132M (Thermal Class F), SF-J(V) 160M~250M (Thermal Class F)

Pole	Output		Frame No.	Full Load Current(A) / Full Load Revolution(r/min)				
	HP	kW		220V 50Hz	380V 50Hz	415V 50Hz	220V 60Hz	440V 60Hz
2	1/4	0.2	63	0.97 / 2810	0.56 / 2810	0.58 / 2840	0.94 / 3360	0.53 / 3380
	1/2	0.4	71	1.73 / 2830	1.0 / 2830	1.0 / 2860	1.65 / 3420	0.9 / 3440
	1	0.75	80	3.1 / 2830	1.8 / 2830	1.8 / 2860	2.9 / 3400	1.6 / 3430
	2	1.5	90L	5.6 / 2860	3.2 / 2860	3.1 / 2870	5.2 / 3440	2.8 / 3450
	3	2.2	90L	7.8 / 2850	4.5 / 2850	4.3 / 2870	7.6 / 3430	4.0 / 3460
	5	3.7	112M	12.8 / 2890	7.4 / 2890	7.2 / 2910	12.6 / 3470	6.5 / 3490
	7.5	5.5	132S	20.1 / 2900	11.6 / 2900	11.6 / 2910	18.9 / 3480	10 / 3500
4	1/4	0.2	63	1.11 / 1430	0.64 / 1430	0.69 / 1440	0.97 / 1730	0.61 / 1750
	1/2	0.4	71	2.0 / 1410	1.15 / 1410	1.2 / 1430	1.8 / 1700	1.0 / 1730
	1	0.75	80	3.3 / 1400	1.9 / 1400	1.95 / 1410	3.0 / 1700	1.7 / 1720
	2	1.5	90L	5.9 / 1430	3.4 / 1430	3.4 / 1440	5.5 / 1710	3.1 / 1730
	3	2.2	100L	8.7 / 1420	5.0 / 1420	4.9 / 1430	8.5 / 1710	4.6 / 1730
	5	3.7	112M	13.7 / 1420	7.9 / 1420	7.7 / 1430	13.5 / 1710	7.2 / 1730
	7.5	5.5	132S	20.4 / 1430	11.8 / 1430	11.1 / 1440	19.9 / 1720	10.3 / 1740
6	1/4	0.2	71	1.21 / 920	0.7 / 920	0.7 / 930	1.12 / 1100	0.65 / 1120
	1/2	0.4	80	2.25 / 920	1.3 / 920	1.3 / 930	2.1 / 1100	1.2 / 1110
	1	0.75	90L	3.6 / 940	2.1 / 940	2.2 / 950	3.5 / 1130	2.0 / 1150
	2	1.5	100L	7.0 / 930	4.0 / 930	4.0 / 940	6.6 / 1110	3.6 / 1120
	3	2.2	112M	9.5 / 940	5.5 / 940	5.4 / 950	9.0 / 1120	5.1 / 1140
	5	3.7	132S	15.2 / 940	8.8 / 940	8.4 / 950	14.2 / 1130	7.8 / 1150
	7.5	5.5	132M	22 / 950	12.8 / 950	13 / 960	21 / 1140	11.5 / 1150

SB-JR(V) IP22 80M~90L(Thermal Class B), 100L~132M (Thermal Class F)

Pole	Output		Frame No.	Full Load Current(A) / Full Load Revolution(r/min)				
	HP	kW		220V 50Hz	380V 50Hz	415V 50Hz	220V 60Hz	440V 60Hz
4	1	0.75	80M	3.5 / 1400	2.0 / 1400	2.3 / 1410	2.9 / 1700	1.7 / 1720
	2	1.5	90L	6.2 / 1450	3.6 / 1450	4.0 / 1460	5.5 / 1720	3.2 / 1740
	3	2.2	100L	8.7 / 1420	5.0 / 1420	4.9 / 1430	8.5 / 1710	4.6 / 1730
	5	3.7	112M	13.7 / 1420	7.9 / 1420	7.7 / 1430	13.5 / 1710	7.2 / 1730
	7.5	5.5	132S	20.4 / 1430	11.8 / 1430	11.8 / 1440	19.4 / 1720	11.2 / 1730
	10	7.5	132M	26.4 / 1440	15.2 / 1440	15.2 / 1450	25.4 / 1730	13.7 / 1740

Three Phase Motor Characteristics

HT (380~415V 50Hz, 380~440V 60Hz)

SF-JR(V) IP55 63M~132M (Thermal Class F), SF-J(V) 160M~250M (Thermal Class F),

SF-JR IP 44 63M~90L 4P (Thermal Class F)

Pole	Output		Frame No.	Full Load Current(A) / Full Load Revolution(r/min)			
	HP	kW		380V 50Hz	415V 50Hz	380V 60Hz	440V 60Hz
2	5	3.7	112M	7.5 / 2890	7.3 / 2910	7.3 / 3470	6.6 / 3490
	7.5	5.5	132S	11.6 / 2900	11.6 / 2910	10.9 / 3480	10 / 3500
	10	7.5	132S	14.4 / 2900	14.0 / 2920	14.2 / 3480	12.4 / 3510
	15	11	160M	21.5 / 2910	20.5 / 2920	21 / 3490	18.5 / 3510
	20	15	160M	28 / 2910	27 / 2920	27 / 3490	24 / 3510
	25	18.5	160L	34 / 2910	33 / 2930	33 / 3490	29 / 3510
	30	22	180M	42 / 2910	39 / 2930	41 / 3490	36 / 3510
	40	30	180L	55 / 2920	52 / 2940	54 / 3490	47 / 3520
	50	37	200L	69 / 2920	67 / 2940	67 / 3510	60 / 3530
	60	45	200L	83 / 2920	80.5 / 2940	81 / 3510	72 / 3530
4	5	3.7	112M	7.9 / 1420	7.7 / 1430	7.8 / 1710	7.2 / 1730
	7.5	5.5	132S	11.8 / 1430	11.1 / 1440	11.5 / 1720	10.3 / 1740
	10	7.5	132M	15.5 / 1430	14.5 / 1440	15.0 / 1720	13.4 / 1740
	15	11	160M	22.5 / 1430	21.5 / 1440	21.5 / 1720	19 / 1740
	20	15	160L	30 / 1450	31 / 1460	28.5 / 1740	26 / 1760
	25	18.5	180M	36 / 1460	35 / 1470	35 / 1750	32 / 1760
	30	22	180M	43 / 1460	42 / 1470	42 / 1750	38 / 1760
	40	30	180L	58 / 1460	56 / 1470	56 / 1750	49 / 1760
	50	37	200L	69 / 1450	65 / 1460	69 / 1750	60 / 1770
	60	45	200L	83.5 / 1450	82 / 1460	82 / 1750	72 / 1770
	75	55	225S	104 / 1460	102 / 1470	101 / 1760	90 / 1770
	100	75	250S	140 / 1470	130 / 1470	140 / 1760	123 / 1750
125	90	250M	179 / 1470	174 / 1470	175 / 1720	155 / 1740	
6	5	3.7	132S	8.9 / 940	8.5 / 950	8.3 / 1130	7.9 / 1150
	7.5	5.5	132M	12.8 / 950	13 / 960	12.1 / 1140	11.5 / 1150
	10	7.5	160M	16.5 / 950	16.5 / 960	16 / 1130	14.5 / 1150
	15	11	160L	24 / 960	24 / 970	23 / 1140	21 / 1160
	20	15	180M	32 / 960	32 / 970	31 / 1150	28 / 1170
	25	18.5	180L	39 / 960	37 / 970	38 / 1150	33 / 1170
	30	22	180L	45 / 960	43 / 970	44 / 1150	39 / 1170
	40	30	200L	60 / 960	59 / 970	58 / 1150	51 / 1170
	50	37	200L	74 / 960	74 / 970	72 / 1150	64 / 1170
	60	45	225S	89 / 960	90 / 975	86 / 1160	76 / 1170

SB-JR(V) IP22 80M~90L(Thermal Class B), 100L~132M (Thermal Class F)

Pole	Output		Frame No.	Full Load Current(A) / Full Load Revolution(r/min)			
	HP	kW		380V 50Hz	415V 50Hz	380V 60Hz	440V 60Hz
4	5	3.7	112M	7.9 / 1420	7.7 / 1430	7.8 / 1710	7.2 / 1730
	7.5	5.5	132S	11.8 / 1430	11.8 / 1440	11.2 / 1720	10.6 / 1730
	10	7.5	132M	15.4 / 1440	15.2 / 1450	14.7 / 1730	13.6 / 1750