

SUPER LINE K SERIES SINGLE PHASE INDUCTION MOTOR



Feature and Benefits

The variety of type of Single Phase Motor based on JIS (Japanese Industrial Standard) and IEC (International Electrotechnical Commission). And being positively advanced under technological assistance contract with MITSUBISHI ELECTRIC JAPAN which have an experience for manufacturing motor since 1907.

Top class of light weighting and down sizing

The best choice of employing steel frame and steel or aluminium bracket (excluding SI-K Type) that enables light weighting and down sizing motor.

High efficiency and high torque

Accumulated techniques and CAE (Computer Aided Engineering) analysis that we found steel frame pass through magnetic field then can manufacture high power and save energy of motor.

Powerful and smooth speed

Due to high efficiency design focused on high acceleration torque and die-cast rotor of rather small moment of inertia enables smooth starting and stopping.

Low vibration and low noise

Our highly technology equipment, the ample rigidity, precise machining of each part and exact balancing of electrical design which makes MEATH motor have low vibration and low noise.

High reliability

Improve to highly reliable insulation system by using thermal class E, B, and F to be standard.

Longer life

Based on selecting the proper bearing size and improving to have highly efficient cooling of bearing housing and steel frame which is greatly affect the longer bearing life.



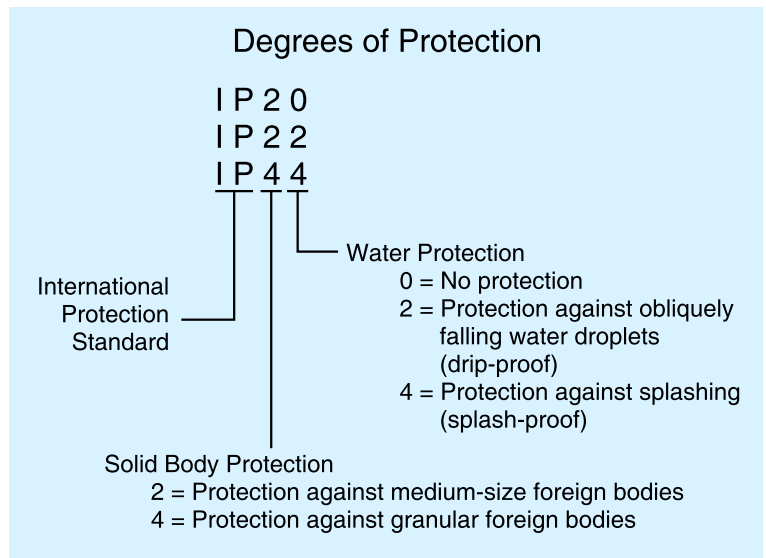
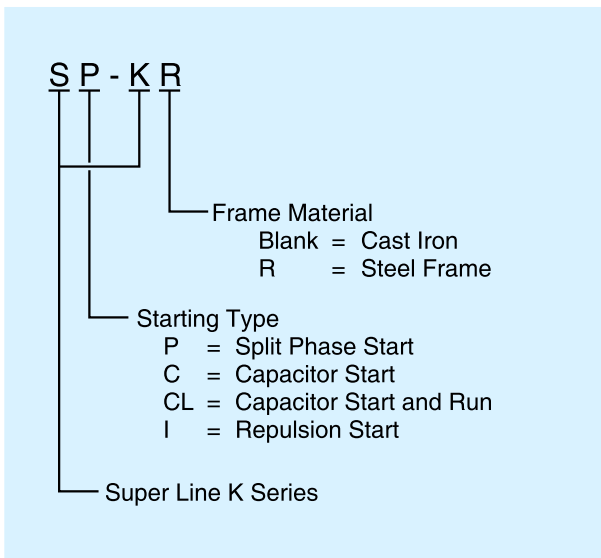

Best and reliable design of centrifugal switch

The best design of centrifugal switch from MITSUBISHI ELECTRIC JAPAN that can manufacture in our highly technology equipment which can be reliable.

Significance of type designations and degrees of protection for single phase motor

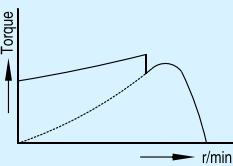
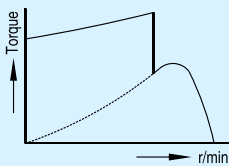
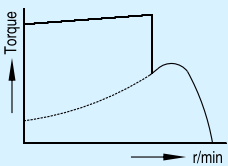
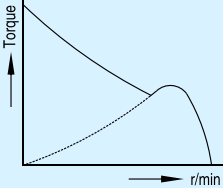
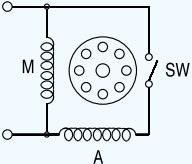
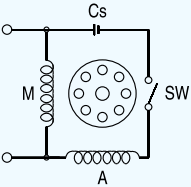
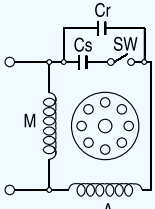
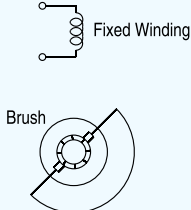

Characteristics and Performance

Item	Motor Type			
	Split Phase Start	Capacitor Start	Capacitor Start and Run	Repulsion Start
Appearance				
Characteristic Curve				
Connection	 <p>M : Main Coil A : Auxiliary Coil SW : Centrifugal Switch</p>	 <p>M : Main Coil A : Auxiliary Coil SW : Centrifugal Switch Cs : Starting Capacitor</p>	 <p>M : Main Coil A : Auxiliary Coil SW : Centrifugal Switch Cs : Starting Capacitor Cr : Running Capacitor</p>	 <p>Fixed Winding Brush</p>
Application	Drilling Machine Blower	Conveyer Pump	Conveyer Compressor	Compressor Agricultural Machine

Item	SP-KR			SC-KR			SCL-KR						SI-K			
	1/4	1/3	1/2	1/4	1/3	1/2	1	1.5	2	3	5	7.5	10	1/2	1	1 3/4
Output (HP)	1/4	1/3	1/2	1/4	1/3	1/2	1	1.5	2	3	5	7.5	10	1/2	1	1 3/4
Frame No.	A71	B71	80M	A71	B71	80M	90S	90L	100L	112M	132S	132M	132ML	100	100	100
No. of Poles	4	4	4	4	4	4	4	4	4	4	4	4	4	4	4	4
Thermal Class	E	E	E	E	E	E	B	B	B	B	F	F	F	E	E	E
Power Supply	1 Phase 220V 50Hz															
Full Load Current (A)	2.8	3.1	4.8	2.6	3.1	4.3	5.2	7.9	10.4	15.1	23	34	44.5	3.5	7.6	12
Full Load Speed (r/min)	1450	1440	1440	1450	1450	1430	1430	1440	1450	1450	1430	1450	1450	1455	1460	1450
Starting Current (A)	20	26.5	34	11	13.5	18.5	32	44	55	95	107	162	215	12.5	25	40
Starting Torque (%)	300	290	200	360	302	273	286	244	203	238	232	193	198	615	480	380
Break Down Torque (%)	310	270	293	280	262	390	250	290	239	260	174	195	187	478	290	250
Power Supply	1 Phase 220V 60Hz															
Full Load Current (A)	2.4	2.8	4.6	2.3	2.8	3.6	4.6	7.1	9.4	13.4	23	33.5	40	3.0	5.9	10.3
Full Load Speed (r/min)	1740	1730	1730	1740	1740	1720	1720	1720	1740	1740	1720	1700	1740	1750	1750	1740
Starting Current (A)	19.5	26	34	10.3	13.3	19.3	32	45	54	73	102	171	208	13.5	27	40
Starting Torque (%)	288	232	161	370	303	251	310	285	260	374	174	203	200	670	548	350
Break Down Torque (%)	299	227	251	283	229	327	265	225	245	202	165	210	170	435	265	227
Net Weight (kg)	6.6	7.5	11	6.8	7.6	11.4	15.2	18.6	23.4	32.8	45.8	60	68.2	26.4	32	36.6

SP-KR SPLIT PHASE START TYPE

Open-Protected Type, IP 20 Degrees of Protection



SP-KR 1/4HP 4P A71

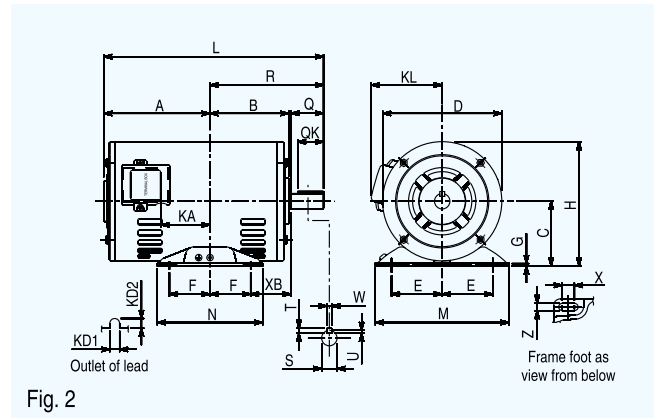
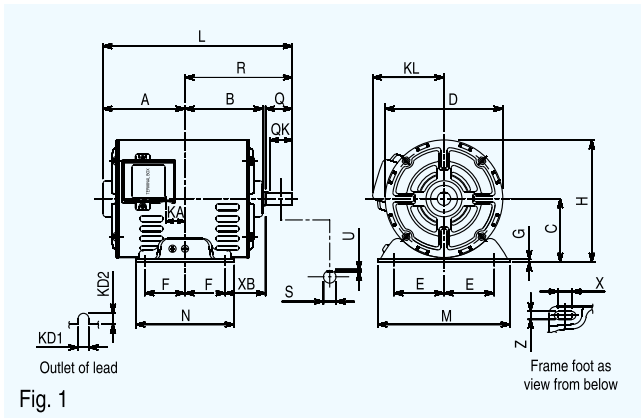

Dimensions (mm)

Model	Frame No.	Output HP (kW)	Pole	Fig.	Motor																	
					A	B	C*	D	E	F	G	H	KA	KD1	KD2	KL	L	M	N	X	XB	Z
SP-KR	A71	1/4(0.2)	4	1	92	87	71	131.2	56	45	3.2	136.6	21.3	12	12	82	212	148	110	15	45	9
	B71	1/3(0.25)	4		101	87	71	131.2	56	45	3.2	136.6	30.3	12	12	82	221	148	110	15	45	9
	80M	1/2(0.4)	4	2	125	97	80	146.6	62.5	50	3.2	153.3	44.5	12	12	92	265	165	130	10	50	10

* The perpendicular variation of tolerance for the shaft center is $\begin{matrix} 0 \\ -0.5 \end{matrix}$

Model	Frame No.	Output HP (kW)	Pole	Fig.	Shaft End							Bearing No.		Approximate Weight (kg)	Approximate Packing Dimensions (LxWxH)	Packing Weight (kg)
					Q	QK	R	S	T	U	W	Drive End	Opposite			
SP-KR	A71	1/4(0.2)	4	1	30	27	120	14 h6	-	1	-	6202ZZ	6201ZZ	6.6	245 x 200 x 184	7.0
	B71	1/3(0.25)	4		30	27	120	14 h6	-	1	-	6202ZZ	6201ZZ	7.5	255 x 200 x 184	8.0
	80M	1/2(0.4)	4	2	40	28	140	16 j6	5	3	5	6203ZZ	6202ZZ	11	300 x 200 x 184	12

SC-KR CAPACITOR START TYPE

Open-Protected Type, IP 20 Degrees of Protection



SC-KR 1/2HP 4P 80M

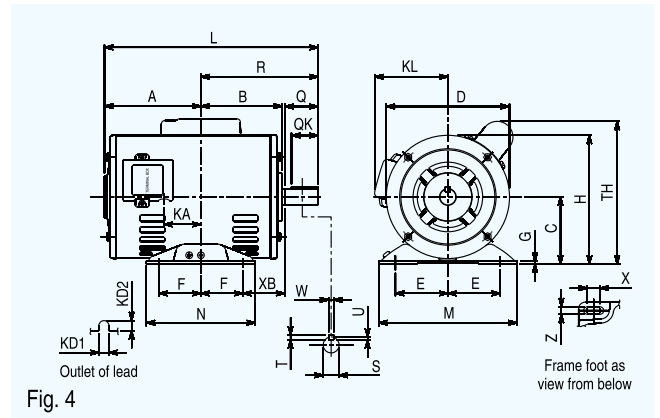
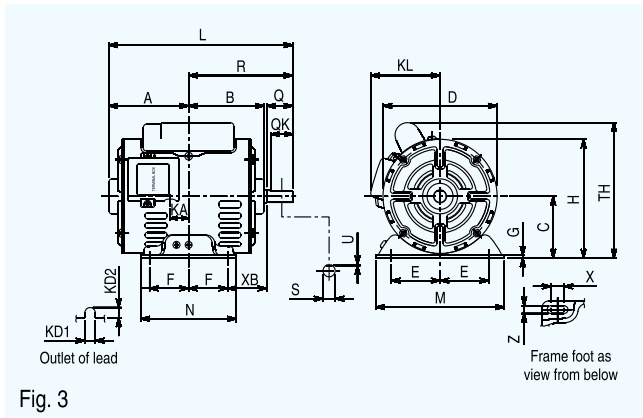

Dimensions (mm)

Model	Frame No.	Output HP (kW)	Pole	Fig.	Motor																		
					A	B	C*	D	E	F	G	H	KA	KD1	KD2	KL	L	M	N	X	XB	TH	Z
SC-KR	A71	1/4(0.2)	4	3	92	87	71	131.2	56	45	3.2	136.6	21.3	12	12	82	212	148	110	15	45	170	9
	B71	1/3(0.25)	4		101	87	71	131.2	56	45	3.2	136.6	30.3	12	12	82	221	148	110	15	45	167	9
	80M	1/2(0.4)	4	4	125	97	80	146.6	62.5	50	3.2	153.3	44.5	12	12	92	265	165	130	10	50	173	10

* The perpendicular variation of tolerance for the shaft center is $\begin{matrix} 0 \\ -0.5 \end{matrix}$

Model	Frame No.	Output HP (kW)	Pole	Fig.	Shaft End						Bearing No.		Approximate Weight (kg)	Approximate Packing Dimensions (LxWxH)	Packing Weight (kg)	
					Q	QK	R	S	T	U	W	Drive End				Opposite
SC-KR	A71	1/4(0.2)	4	3	30	27	120	14 h6	-	1	-	6202ZZ	6201ZZ	6.8	245 x 200 x 184	7.5
	B71	1/3(0.25)	4		30	27	120	14 h6	-	1	-	6202ZZ	6201ZZ	7.6	255 x 200 x 184	8.2
	80M	1/2(0.4)	4	4	40	28	140	16 j6	5	3	5	6203ZZ	6202ZZ	11.4	300 x 200 x 184	12

SCL-KR CAPACITOR START AND RUN TYPE

Drip-proof Type, IP 22 Degrees of protection



SCL-KR 10HP 4P 132ML

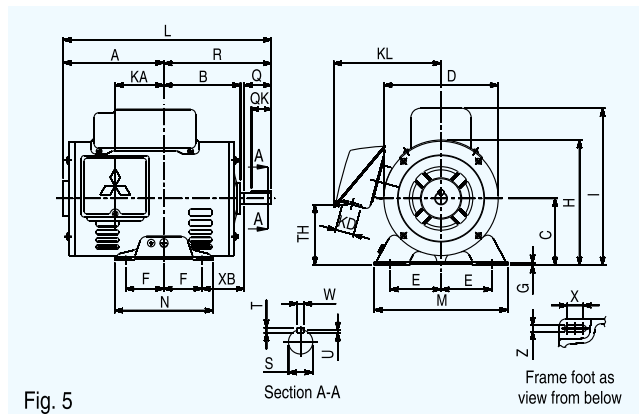

Fig. 5

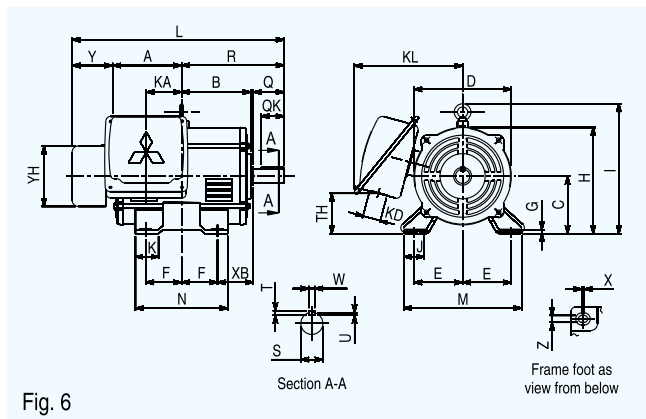

Fig. 6

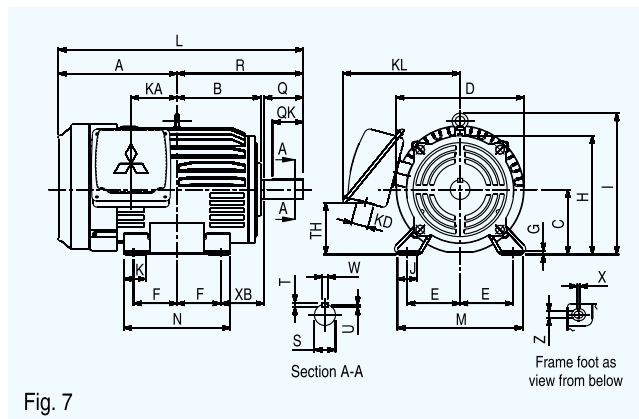

Fig. 7

Dimensions (mm)

Model	Frame No.	Output HP (kW)	Pole	Fig.	Motor																						
					A	B	C*	D	E	F	G	H	I	J	K	KA	KD	KL	L	M	N	XB	TH	Y	YH	X	Z
SCL-KR	90S	1(0.75)	4	5	132	103	90	165.7	70	50	3.2	173	220	-	-	68	27	157	278	175	125	56	81	-	-	10	10
	90L	1.5(1.1)	4		120	115	90	165.7	70	62.5	4	173	220	-	-	55	27	157	313	175	150	56	81	-	-	15	9
	100L	2(1.5)	4	6	118	128	100	168	80	70	6.5	184	-	40	45	65	35	201	400	200	180	63	64	89	118	4	12
	112M	3(2.2)	4		125	135	112	190	95	70	6.5	207	254	40	45	69	35	211	414	230	180	70	79	89	118	4	12
	132S	5(3.7)	4	7	223	152	132	266	108	70	6.5	242	289	40	45	75	27	215	462	256	180	89	117	-	-	4	12
	132M	7.5(5.5)	4		242	171	132	266	108	89	6.5	242	289	40	45	94	35	240	500	256	218	89	106	-	-	4	12
	132ML	10(7.5)	4		270	171	132	266	108	89	6.5	242	289	40	45	122	35	240	528	256	218	89	106	-	-	4	12

* The perpendicular variation of tolerance for the shaft center is $\begin{matrix} 0 \\ -0.5 \end{matrix}$

Model	Frame No.	Output HP (kW)	Pole	Fig.	Shaft End						Bearing No.		Approximate Weight (kg)	Approximate Packing Dimensions (LxWxH)	Packing Weight (kg)	
					Q	QK	R	S	T	U	W	Drive End				Opposite
SCL-KR	90S	1(0.75)	4	5	40	28	146	19 j6	6	3.5	6	6204ZZ	6202ZZ	15	368 x 280 x 250	16
	90L	1.5(1.1)	4		50	40	168.5	24 j6	7	4	8	6205ZZ	6203ZZ	18.6	390 x 280 x 250	18.2
	100L	2(1.5)	4	6	60	45	193	28 j6	7	4	8	6206ZZ	6205ZZ	24.5	437 x 355 x 300	25.4
	112M	3(2.2)	4		60	45	200	28 j6	7	4	8	6207ZZ	6206ZZ	32.8	504 x 411 x 327	39
	132S	5(3.7)	4	7	80	63	239	38 k6	8	5	10	6308ZZ	6207ZZ	45.8	552 x 438 x 359	53
	132M	7.5(5.5)	4		80	63	258	38 k6	8	5	10	6308ZZ	6207ZZ	60.0	602 x 475 x 369	68
	132ML	10(7.5)	4		80	63	258	38 k6	8	5	10	6308ZZ	6207ZZ	68.2	630 x 475 x 369	76

SI-K REPULSION START TYPE

Totally Enclosed Type, IP 44 Degrees of Protection



SI-K 1HP 4P 100

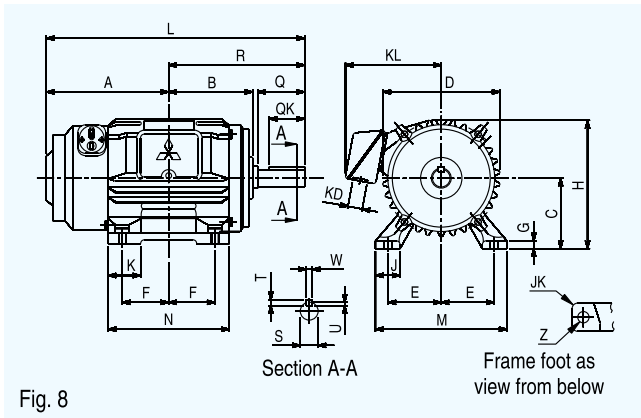

Fig. 8

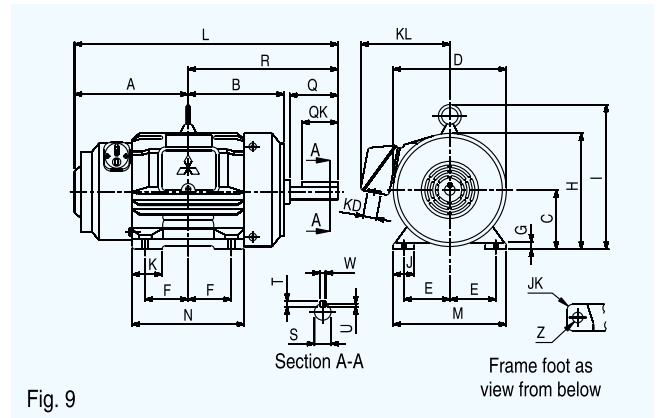

Fig. 9

Dimensions (mm)

Model	Frame No.	Output HP (kW)	Pole	Fig.	Motor																	
					A	B	C*	D	E	F	G	H	I	J	JK	K	KD	KL	L	M	N	Z
SI-K	100	1/2(0.4)	4	8	170.5	128	100	208	80	70	12	204	-	40	3	40	27	161	343.5	200	175	12
	100	1 (0.75)	4	9	170.5	168.5	100	212	80	70	12	206	237.5	40	3	40	27	161	383.5	200	175	12
	100	1 3/4 (1.3)	4		185.5	168.5	100	212	80	70	12	206	237.5	40	3	40	27	161	398.5	200	175	12

* The perpendicular variation of tolerance for the shaft center is $\frac{0}{-0.5}$

Model	Frame No.	Output HP (kW)	Pole	Fig.	Shaft End						Bearing No.		Approximate Weight (kg)	Approximate Packing Dimensions (LxWxH)	Packing Weight (kg)	
					Q	QK	R	S	T	U	W	Drive End				Opposite
SI-K	100	1/2(0.4)	4	8	40	28	173	16 j6	5	3	5	6205ZZ	6203ZZ	26.4	395 x 309 x 258	28.2
	100	1 (0.75)	4	9	40	36	213	22 j6	7	4	8	6205ZZ	6203ZZ	32.0	424 x 309 x 258	34
	100	1 3/4 (1.3)	4		40	36	213	24 j6	7	4	8	6206ZZ	6204ZZ	36.6	522 x 372 x 320	43.6

Standard Specifications

Item		Specifications																									
Voltage and Frequency		220~230V 50Hz, 220V 60Hz																									
Starting Method, Enclosure Construction and Degrees of Protection		<table border="1"> <thead> <tr> <th>Starting Method</th> <th>Model Name</th> <th>Frame No.</th> <th>Enclosure Construction</th> <th>Degrees of Protection</th> </tr> </thead> <tbody> <tr> <td>Split Phase Start</td> <td>SP-KR</td> <td>A71 ~ 80M</td> <td>Opened Protected</td> <td>IP20</td> </tr> <tr> <td>Capacitor Start</td> <td>SC-KR</td> <td>A71 ~ 80M</td> <td>Opened Protected</td> <td>IP20</td> </tr> <tr> <td>Capacitor Start and Run</td> <td>SCL-KR</td> <td>90S ~ 132ML</td> <td>Drip-proof</td> <td>IP22</td> </tr> <tr> <td>Repulsion Start</td> <td>SI-K</td> <td>100</td> <td>Totally Enclosed</td> <td>IP44</td> </tr> </tbody> </table>	Starting Method	Model Name	Frame No.	Enclosure Construction	Degrees of Protection	Split Phase Start	SP-KR	A71 ~ 80M	Opened Protected	IP20	Capacitor Start	SC-KR	A71 ~ 80M	Opened Protected	IP20	Capacitor Start and Run	SCL-KR	90S ~ 132ML	Drip-proof	IP22	Repulsion Start	SI-K	100	Totally Enclosed	IP44
		Starting Method	Model Name	Frame No.	Enclosure Construction	Degrees of Protection																					
		Split Phase Start	SP-KR	A71 ~ 80M	Opened Protected	IP20																					
		Capacitor Start	SC-KR	A71 ~ 80M	Opened Protected	IP20																					
		Capacitor Start and Run	SCL-KR	90S ~ 132ML	Drip-proof	IP22																					
Repulsion Start	SI-K	100	Totally Enclosed	IP44																							
Frame Material		SP-KR, SC-KR, SCL-KR : Steel Plate SI-K : Cast Iron																									
Thermal Class		SP-KR, SC-KR, SI-K : Class E SCL-KR 90S ~ 112M : Class B 132S ~ 132ML : Class F																									
Circumstance Condition	Ambient Temperature	-20 ~ +40°C																									
	Ambient Humidity	85% RH or less (for Opened Protected & Drip-proof Structure) 95% RH or less (for Totally Enclosed Structure)																									
	Altitude	Less than 1,000m above sea level																									
	Environment	No bursting / erosive gas or vapor																									
Coating Colour		Munsell N5.5 (Gray)																									
Conformed Standard		IEC 60034-1 & JIS C 4203 (for SP-KR, SC-KR), JEC-2137-2000 (for SCL-KR, SI-K)																									

Connection

